



OWNER'S MANUAL

- **Safety**
- **Assembly**
- **Preventive Maintenance
& Troubleshooting**

The
Designer
System®

 **WARNING**

Before assembling, operating, or maintaining a Designer System[®] conveyor, read and understand this Manual. Failure to follow instructions and safety precautions could result in serious injury, death or property damage.

Table of Contents

Foreword	5
For Your Records	5
Safety	6
Installation Safety	6
Control Stations	6
Safety Inspections	7
Design Changes	7
Span Tech Parts	7
Major Causes of Conveyor-Related Injuries	7
Prohibited Environments	8
In Case of Fire	8
Maximum Load and Speed	8
Designer System Operation	9
Safety Signal Words - Definitions	10
Safety Labels	10
Illustrations of Labels (U.S. versions)	11
Illustrations of Labels (international versions)	12
Assembly Guide	13
Introduction	13
Before You Begin	14
List of Tools Required	15
Getting Started	16
Pre-Assembly Checklist	16
Step 1 - Uncrate and Lay Out Bed Sections	17
Step 2 - Assemble Bed Sections	18
Step 3 - Install Center Support Rails	20
Step 4 - Install and Inspect Wearstrips	22
Step 5 - Install Guide Rail and Return Chain Support Rail	25
Step 6 - Install Support Structures	27
Step 7 - Install Conveyor Chain	29
Step 8 - Install / Remove Gearmotor	33
Step 9 - Install Transfer Bridge - Gravity Roller Transfer	40
Step 10 - Install Transfer Bridge - MicroSpan Transfer	41
Pre-Operation Safety Checklist	43

(continued on next page)

Table of Contents (continued)

Preventive Maintenance and Troubleshooting	45
Safety Guidelines and Information	45
Routine Preventive Maintenance	46
1 - Environmental Contamination Inspection	46
2 - Chain and Wearstrip Inspection	47
3 - Drive / Idler Wearstrip and Side Plate Inspection	48
4 - Foreign Object Interference Inspection	49
5 - Chain Slack and Sprocket Engagement Inspection	50
6 - Lubrication and Lubricator Inspection	51
7 - Measurement of Motor Current	52
Preventive Maintenance Items Checklist	53
 Maintenance Procedures	 54
Part A: Preventing Environmental Contamination	54
Part B: Cleaning	55
Part C: Wearstrip Installation	57
Part D: Overheated Wearstrips	63
Part E: Drives and Idlers	64
Part F: Lubricator Adjustment	67
Part G: Powered Transfer Lubrication	68
Part H: Motor Amperage & Gearbox Temperature	69
Part I: Sprocket Orientation	71
Part J: Sprocket Alignment	72
Part K: Sprocket Installation	73
Part L: Chain-to-Sprocket Engagement and Chain Installation Direction	74
Part M: Sprockets Rubbing Side Plates	75
Part N: Bound or Locked Idler Shaft	76
Part O: Broken or Bent Chain Rods	77
Part P: Chain Assembly	78
Part Q: Center Support Rail	79
Part R: Return Chain Support Rail	81
Part S: Direction of Bed Sections	82
Part T: Side Frame Alignment	83
Part U: Horizontal & Vertical Bend to Straight Bed Section Alignment	84
Part V: Crossbars	86
Part W: Chemical Contamination	87
Part X: Chain Pitch & Elongation	88
 Chemical Compatibility Chart	 90
 Troubleshooting	 98
Troubleshooting Diagnostic Chart	99

Foreword

This manual has been prepared for those persons who will assemble, operate, or maintain a Designer System[®] conveyor. It is important that **all** persons responsible for the care and operation of this product READ and UNDERSTAND the information contained in this publication.

This manual covers four major subject areas related to the Designer System[®] family of conveyors:

1. **Safety** requirements and precautions.
2. **Assembly** of Designer System[®] conveyors.
3. **Preventive Maintenance** procedures for Designer System[®] conveyors.
4. **Troubleshooting** information and assistance.

For Your Records

Included with each conveyor system are the following papers; make sure you have them all for your records:

- Final Bill of Materials
- Owner's Manual (this document)
- Master Project Layout Drawings

Safety

Installation Safety

Installation of a Designer System® conveyor should be performed only by trained and experienced personnel who have read all of the literature that accompanied this shipment.

All electrical installations and wiring should conform to the National Electrical Code.

Each control station should be clearly labeled, and should be located so that the operation of the conveyor is visible from the control station.

Guards, safety devices, and safety labels should be installed in the correct locations and maintained in good repair.

Support systems for the conveyor should be securely anchored.

Control Stations



Lockout the electrical power to the conveyor motor in accordance with OSHA regulations prior to system maintenance. Failure to comply could result in serious injury or death.

The conveyor should not be started until all personnel in the area have been alerted by an automated signal or by a designated person. Do not start equipment until all applicable personnel are aware of your intention and are clear of components to be energized. Once personnel have been properly alerted, the conveyor may be started.

Only trained and qualified personnel may perform maintenance or repair tasks on a control station.

Safety Inspections

Evaluation After Installation

After installation of the conveyor system, the user should perform an initial on-site safety evaluation. The Pre-Operation Safety Checklist (*page 43*) should be used. Additional safety labels (if needed) should be ordered at this time, before operations begin.

Pre-Operation Safety Checklist (form)

The Pre-Operation Safety Checklist is shown on *page 43*. All “No” entries on the evaluation require corrective action.

User Safety Evaluation Log

The user should maintain an ongoing safety evaluation log. The log will consist of the most recent completed Pre-Operation Safety Checklists. User safety evaluations should be performed monthly.

Design Changes

Making changes to the equipment may create serious hazards. The user should not make changes which affect the design, construction, installation, or handling requirements of the equipment without the written consent of the manufacturer.



Do not mount brackets or other items on side frame that extend above or below the chain surface, as this could create pinch points and the possibility of injury.

Span Tech Parts

Only parts supplied or authorized by Span Tech, LLC may be used on the conveyor system.

Major Causes of Conveyor-Related Injuries

The major causes of conveyor-related injuries include:

- Inability to rapidly halt conveyor motion
- Exposed drive components
- Shear points and pinch points caused by moving components, product, or product carriers
- Falling objects

The precautions, recommendations, and instructions provided in the Safety section (*pages 6 through 11*) and throughout this Manual should be understood and followed, as a necessary part of a comprehensive effort to minimize conveyor-related hazards.

Prohibited Environments

In certain environments, Designer System® conveyors should not be used. If you are unsure of the safety or suitability of your intended environment, contact a qualified Span Tech representative. Never use a Designer System® conveyor in any of the following environments:

- Where chemicals that react with Celcon acetal copolymer are used
- Where machining chips are present
- Where fiberglass dust can come into contact with the conveyor
- Where broken glass occurs
- Where small metal particles are present
- Where strong acids or caustics are present
- Where ultraviolet light is present
- Where flammable materials are present (i.e. gasoline, solvents, etc.)

In Case of Fire

WARNING

The acetal material of the conveyor chain burns with a very hot, very faint flame. In case of fire, use Water, Foam, CO₂, or Dry Chemical extinguishers only. Use of other material will not extinguish the fire and could result in serious injury, death or significant property damage.

If a Designer System® acetal conveyor chain were to catch fire, a blue flame would be barely visible, and little or no smoke would be produced. In case of fire, immediately stop conveyor system operation. The fire can then be extinguished using a water, foam, CO₂, or dry chemical fire extinguisher. Report any fire to the applicable Fire Department and plant management personnel immediately. Do not re-operate conveyor until all repairs have been made.

Maximum Load and Speed

The maximum rated load capacity of any Designer System® conveyor is a function of the total load (sum of the weights of the chain and conveyed product) and speed. Contact Span Tech for additional information regarding load capacities.

NOTICE

Do not exceed Span Tech guidelines regarding maximum load and speed of conveyors and related equipment. Failure to comply could result in premature component wear and conveyor failure.

Designer System® Operation

WARNING

Before operating a Designer System® conveyor, read and understand this manual. Failure to follow instructions and safety precautions could result in serious injury, death or property damage.

Only trained employees should be permitted to operate a Designer System® conveyor. Personnel should be trained to safely and properly operate the conveyor under normal conditions and emergency situations.

All personnel working in the vicinity of the conveyor should be instructed as to the location and operation of normal and emergency stopping devices. In the case of an Emergency Stop, the conveyor controls should be arranged so that manual reset or start must be accomplished from where the stop was initiated.

The conveyor should not be started until all personnel in the area have been alerted by a signal or by a designated person. Use the *Pre-Operation Safety Checklist* on page 43 whenever conveyor is to be started or restarted. Restart the conveyor system at the device or location from which it has been stopped.

The system should only be started with all safety devices, safety guards and safety labels in good repair and in place.

Keep clear of the conveyor area when equipment is energized; conveyor may start at any time.

Keep obstructions away from all areas where the conveyor is loaded and unloaded.

Do not place articles or extremities into conveyor chain or frame while in operation.

Secure any loose clothing or hair; remove all jewelry, finger rings, pocket key rings, etc.

Watch for low clearance points and the potential for falling overhead objects.

Safety Signal Words – Definitions

Below are signal words that are used in this manual and in the safety labels to identify different levels of risk.

- **DANGER** indicates a hazardous situation which, if not avoided, will result in death or serious injury.
- **WARNING** indicates a hazardous situation which, if not avoided, could result in death or serious injury.
- **CAUTION** indicates a hazardous situation which, if not avoided, could result in minor or moderate injury.
- **NOTICE** deals with practices where property damage, inefficient work practices, and not injury, are possible consequences.
- The **SAFETY ALERT** symbol (an exclamation point within an equilateral triangle) indicates the need for alertness to a potentially hazardous situation.



Safety Labels

Safety labels are not intended and must not be considered as substitutes for aggressive on-site safety practices.

The following two pages feature illustrations of the safety labels provided with conveyors from Span Tech, LLC. Page 11 shows labels formatted for use in the United States; page 12 shows labels formatted for international use. Labels will become worn with normal conveyor use; these worn labels should be promptly replaced with new labels obtained from Span Tech.

Span Tech replacement safety labels (U.S. versions) are provided as two gang labels; one having two elements and the other having three elements. The part numbers for the two replacement safety labels are:



Part number (label 1): DS8008



Part number (label 2): DS8009

Safety Labels – United States

 <p>www.spantechllc.com</p>	<p>⚠ WARNING</p> <p>To prevent serious injury or death:</p> <ul style="list-style-type: none">• Do not operate or maintain this conveyor until you have read all safety precautions in manual and on labels.• If manual is missing, obtain replacement from Span Tech.
--	--

	<p>⚠ WARNING</p> <p>To prevent serious injury or death, do not operate with loose clothing, long hair, or loose jewelry.</p>
---	---

	<p>⚠ WARNING</p> <p>Fall Hazard</p> <p>Do not stand on conveyor.</p>
--	--

	<p>⚠ WARNING</p> <p>Crush Hazard</p> <ul style="list-style-type: none">• Keep hands clear of moving components.• Equipment starts automatically.• Lock out / tag out equipment before servicing.
---	--

	<p>⚠ WARNING</p> <p>Burn Hazard</p> <p>If conveyor chain (acetal plastic) catches on fire, it burns with a very hot, very faint flame.</p>
---	--

Safety Labels – International



The part number for the replacement international safety label is: **DS8007**



Read Owner's Manual



Entanglement Hazard.
Do not operate with loose clothing, long hair, or loose jewelry.



Fall Hazard
Do not stand on conveyor.



Crush Hazard
Keep hands clear of moving components.



Lock out / tag out equipment before servicing.

Assembly Guide

Introduction

Span Tech has designed the Assembly Guide as a reference to assist you in assembling your new Span Tech conveyor system. To ensure a smooth and efficient assembly process, it is important to take the time to read this manual thoroughly, and to become familiar with the terminology and conveyor components. Reviewing the Spare Parts Illustrations that have been supplied to you will also help you become familiar with the various conveyor components and how they relate to each other. If a question arises during assembly, feel free to contact Span Tech for technical assistance. (Contact information located on back cover.) Keep in mind that each Span Tech conveyor system is customized, and no two installations will be exactly the same.

WARNING

Before assembling a Designer System® conveyor, read and understand this manual. Failure to follow instructions and safety precautions could result in serious injury, death or property damage.

Before You Begin

Before starting assembly, the following **two precautions** must be addressed. These precautions are very important.

NOTICE

Damage caused by a failure to follow the two precautions below will not be covered under the Span Tech conveyor system warranty.

1. Remove Environmental Contaminants

Span Tech conveyor systems must be kept clean during installation to ensure proper operation. Environmental debris can damage a conveyor. Examples of environmental contaminants include concrete dust, sand, paper and wood dust, metal chips, glass, and ceramic dust. Construction in or near the assembly area is a common source of these contaminants.

Avoid assembling the conveyor system when any type of construction is underway in the vicinity of the assembly site. If construction work is to occur at any time after the conveyor system is installed, cover the system completely to prevent contamination.

Do not place the conveyor components where they will be exposed to sunlight. UV (ultraviolet) rays will cause deterioration of plastic components. If components must be stored outdoors, they must be protected from both environmental dirt and sunlight.

2. Handle the Conveyor Components Carefully

Span Tech conveyor systems should never be handled directly by a forklift or any other type of lift truck. Your conveyor will arrive on skids. These skids should be moved as close as possible to the installation area. Two or more able-bodied persons should be able to safely move any of the conveyor's components and field-broken assembly sections.

TOOLS REQUIRED

The following tools will be needed during installation of your conveyor system:

- 1/2" (or 13mm) electric drill
- 13/64" (.2040") (5.5mm) drill bit
- Ratchet, with 10mm socket and 1/2" (or 13mm) socket
- 1/2" (or 13mm) combination wrench
- Hand-held countersink, or 3/8" – 1/2" (10mm – 13mm) drill bit
- Flashlight or other portable light
- At least four (4) saw horses, matched to the height of the conveyor to be installed
- Felt tip marker
- Centering punch
- Flat screwdriver, small
- Rubber mallet
- Hammer
- Tape measure
- Alignment tool (5/32" [4mm] or 3/16" [5mm] recommended size – long tapered point assists in aligning holes)
- Blade & Anvil type pruning shears (*Figure 1A*)
- Rivet Insertion Tool (*Figure 1B*)



Figure 1A: Blade & Anvil pruning shears



Figure 1B: Rivet Insertion Tool

* Supplied with Span Tech Tool Box

Getting Started

Along with this Manual, you should have a schematic drawing of the conveyor system to be assembled. Use the schematic to help prepare the installation site and to ensure that you have all of the required components. Allow enough room in the work area to handle the components with ease. Remember, the cleaner the installation site, the better the conveyor operation. Thorough preparation beforehand will pay off during and after assembly.

Span Tech conveyor systems require a minimum of two (2) people for assembly. When the installation site has been prepared and the all needed tools and personnel are present, assembly may begin. Span Tech conveyor systems are designed and built to be field assembled with minimum effort.

NOTICE

Parts should never be forced together. If a problem arises, please call Span Tech for technical assistance. It is better to take the time to make a telephone call than to risk damaging the conveyor system.

PRE-ASSEMBLY CHECKLIST

- No forklifts or lift-trucks are being (or have been) used to move any part of the conveyor.
- All of the tools included in the “Tools Required” list (*page 15*) have been gathered and are readily available.
- All of the conveyor prints supplied are readily available for reference.
- All of the conveyor components are clean.
- The assembly area is roomy and clean.
- There are at least two qualified people to do the assembly work.

STEP 1 — Uncrate and Lay Out Bed Sections

- Lay out the bed sections and components of the conveyor according to the schematic. While doing this, make sure all bed sections and components are positioned right side up, and in the correct direction according to chain flow, to avoid confusion and error during the actual assembly.

Notice that labels have been attached to the side frame, near the end of each bed section field break (*Figure 2*). These labels indicate the bed section’s conveyor number, joint number, the top side of the bed section, and the direction of chain flow. The joint number on the label of one bed section will match the joint number on the label of the adjoining bed section. These labels should be removed after assembly has been completed.

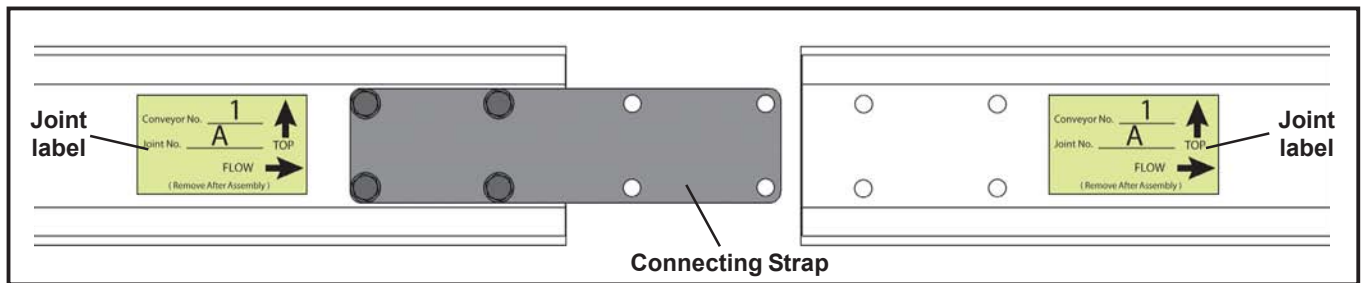

Figure 2: Conveyor Bed Section with joint labels

“Chain flow” refers to the direction in which the chain moves along the top of the conveyor. Most conveyors are designed with the chain “pulled” at the drive end, so that the chain flows from the idler to the drive. The opposite is true for conveyors designed so that the chain is “pushed” at the drive end. The direction of chain flow should be indicated on the schematic drawing, as well as on the label attached to each component or field-broken bed section.

NOTICE

It is very important to keep your Span Tech conveyor system clean to ensure proper operation. Keep this in mind when laying out the system.

Conveyors that will not fit onto one skid for shipping will be field-broken. The sections will have pre-trimmed wearstrips, center support rails, and other accessories. These sections will only need to be connected.

⚠ WARNING

Never step or walk on any part of the conveyor before, during, or after assembly. Doing so could result in serious injury or damage to the conveyor system.

STEP 2 — Assemble Bed Sections

Begin assembly at one end of the conveyor, and work toward the other end. If the system was not shipped with the supports in place, assemble the bed sections on saw horses. The height of the saw horses should place the conveyor at its final elevation. If you are assembling a relatively long system and have only a limited number of saw horses, you can “leapfrog” the saw horses as you move along.

NOTICE

The adjoining bed sections must be bolted together using the steel connecting straps provided.

- Pull any trailing wearstrips at the ends of the bed sections away from the conveyor side frame¹ so they will not interfere while connecting the bed sections (*Figure 3*).

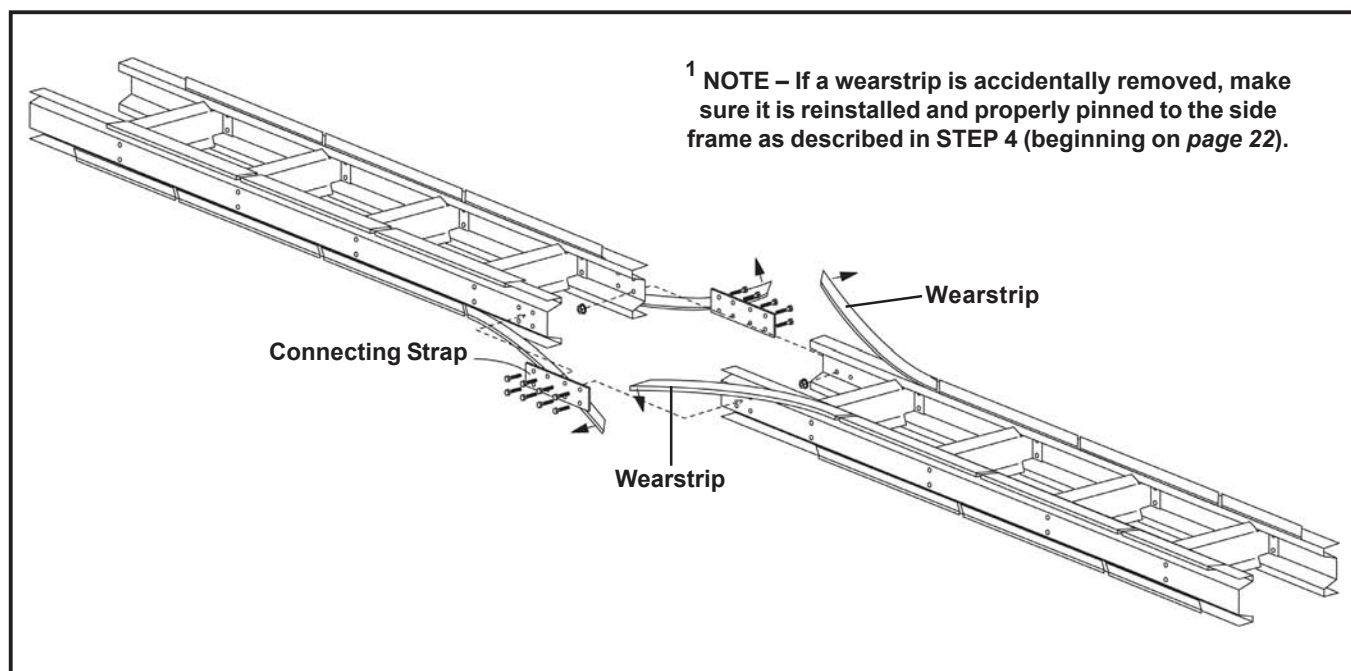

Figure 3: Overview of Bed Section assembly

- Remove the four bolts from the loose end of each connecting strap.
- Loosen the four remaining, attached bolts on each connecting strap.
- Bring the adjoining ends of the bed sections together, lining up the side frames on both sides (*Figure 4*).

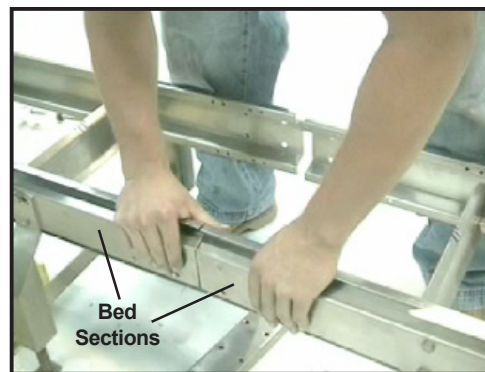

Figure 4: Bring ends of Bed Sections together

STEP 2 — Assemble Bed Sections (continued)

- Insert bolts through the connecting straps and holes in the side frame. NOTE: You will need to leave one hole open, so you can use an alignment tool to help align the frames. After this step there should be four bolts in one end of the strap and three bolts in the other end, with one open hole (Figure 5).
- Using a 1/2" (13mm) wrench, tighten the four bolts in one end of the connecting strap (Figure 5).
- Insert an alignment tool into the open hole, and draw the two frames together (Figure 6). Ensure that the frames are aligned (Figure 7) by feeling the connection with your fingers.
- Tighten all remaining bolts. Install and tighten a bolt in the empty hole.
- Push the wearstrips into position on the lips of the side frames. Be sure the wearstrips are snug against the side frames.
- Repeat assembly procedure for all remaining bed sections; inspect all joints for correct and accurate alignment (Figure 7).

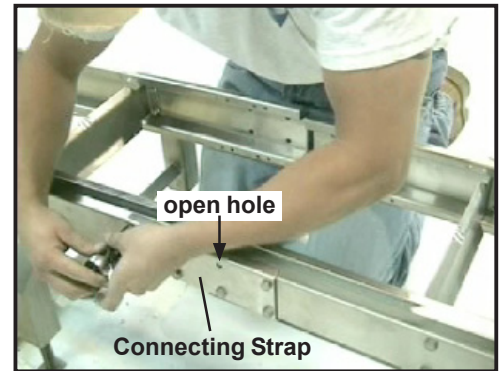

Figure 5: Tighten first four bolts

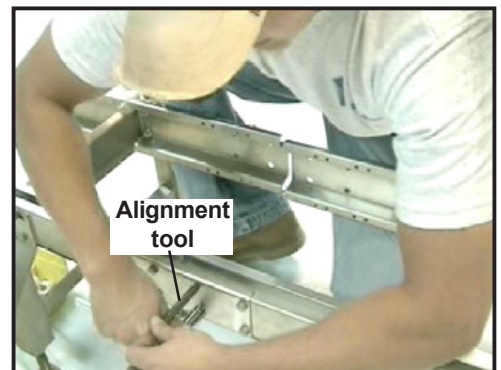

Figure 6: Use alignment tool (in open hole) to draw Bed Sections together

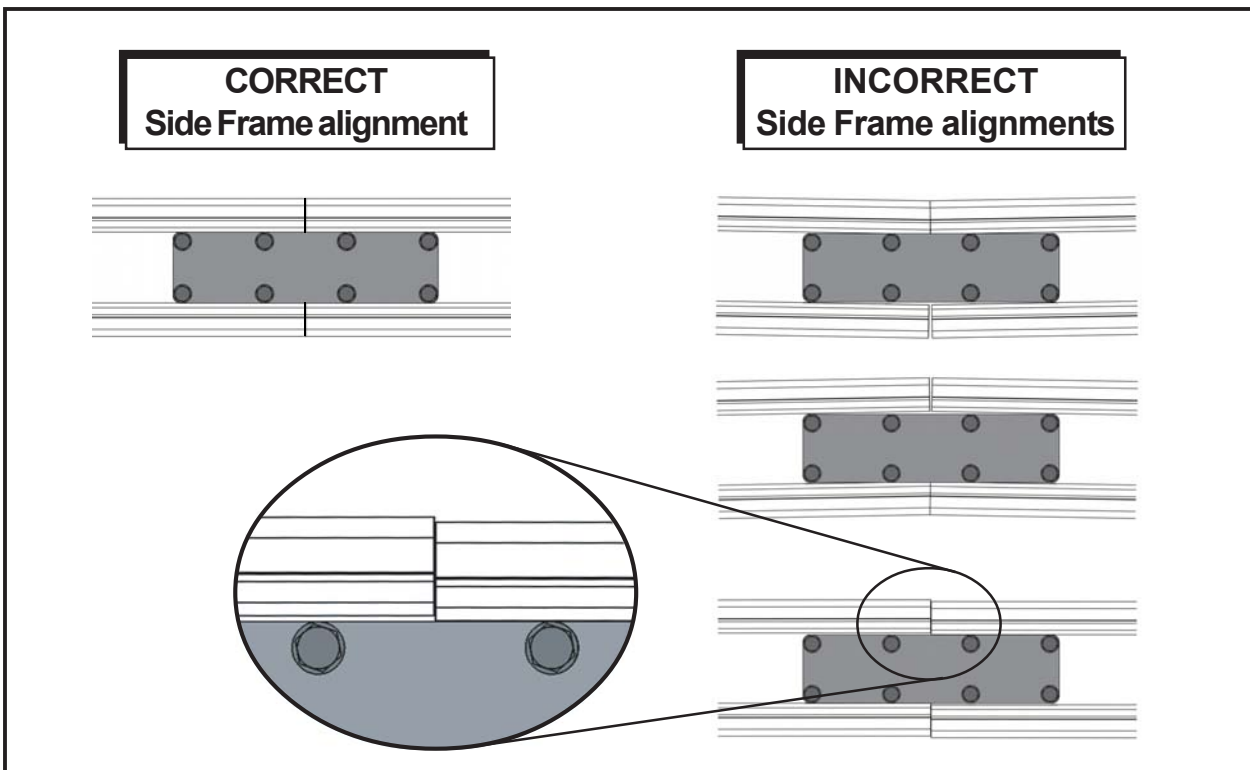

Figure 7: Side Frame misalignment illustrations

STEP 3 — Install Center Support Rails

After the bed sections have been bolted together, the center support rails can be installed. The center support rails (T-rails) provide support for the top chain in the product zone (*Figure 8*), thus preventing the chain from bowing due to the product load. NOTE: *As a rule of thumb, MonoSpan® conveyors and MultiSpan® conveyors that are less than 13.21 inches (335.60 mm) wide do not require center support rails.*

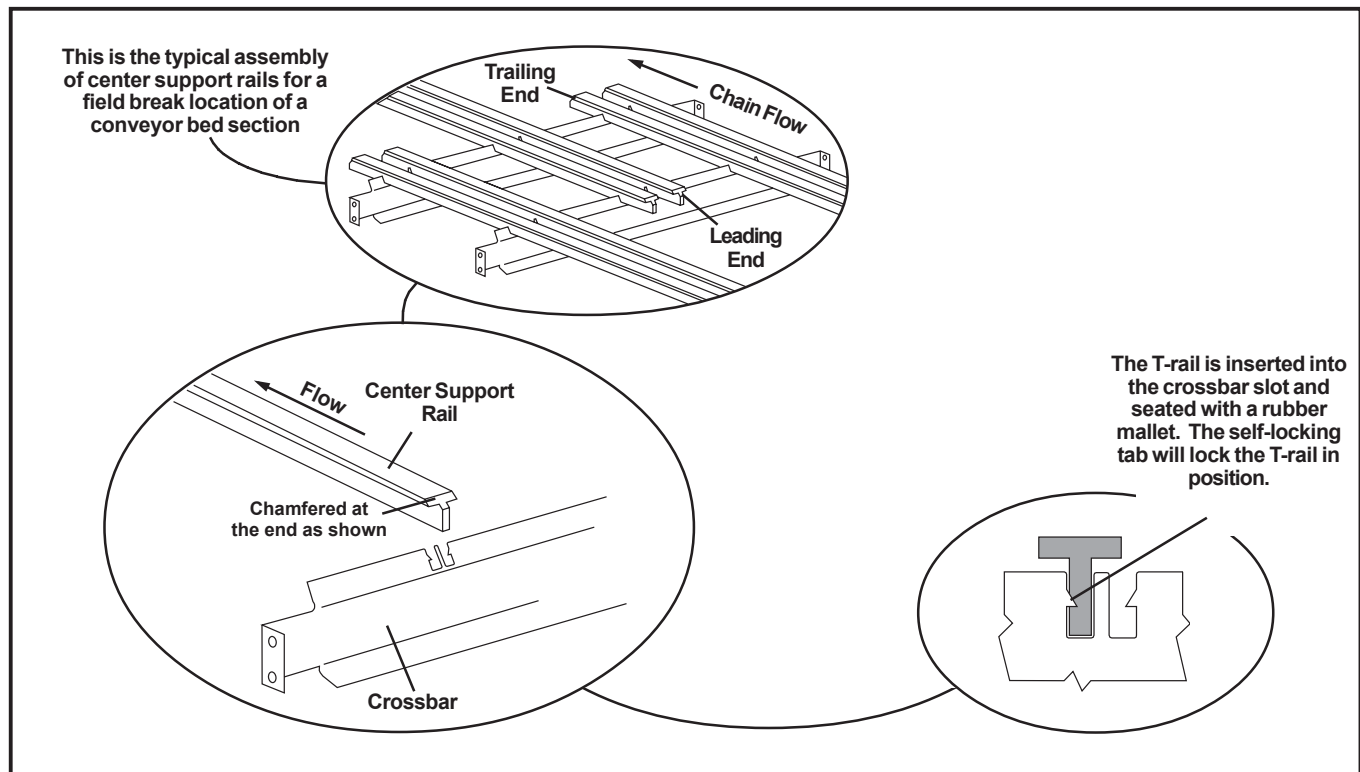

Figure 8: Overview of Center Support Rail assembly

- At field-break locations, insert the T-rail into the crossbar slot closest to the edge of the conveyor.
- Using a rubber mallet, tap the T-rail to fully seat it in the crossbar slot. The self-locking tab will lock the T-rail in position (*see Figure 8*).
- At the next crossbar, insert the T-rail into the *second* slot, so that the T-rail curves slightly. Use a rubber mallet to seat the T-rail in its slot.
- Keep alternating between these two crossbar slots until the entire T-rail is in place.
- Repeat the above steps for all adjacent T-rails, so that the rails create a “wavy” pattern along the entire length of the conveyor (*Figure 9*).
- Inspect entire Center Support Rail to ensure that it is properly installed and secure at every crossbar.

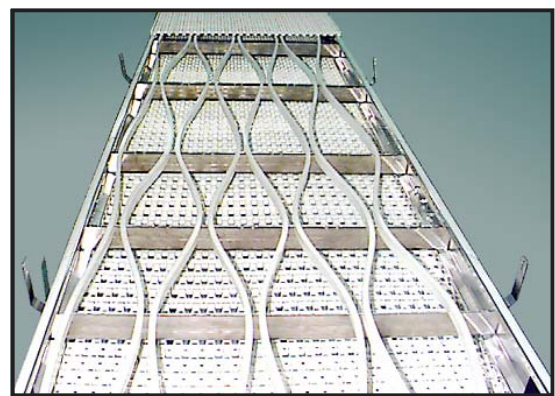

Figure 9: Typical Center Support Rail layout

STEP 3 — Install Center Support Rails (continued)

Center support rails should “snake” back and forth throughout the length of the conveyor to avoid wear in one particular spot (*Figure 9*). The trailing end of a rail should extend beyond the leading end of the next rail (as shown in *Figure 8*) so that support is not interrupted. As a general rule of thumb, MaxiSpan® conveyors will have one center support rail weaving under each of the chain’s center links. MultiSpan® conveyors will require a variable number of center support rails, depending on the specific chain pattern. The number of center support rails for your system was specified at the time of purchase and should be indicated on the schematic.

NOTICE

A center support rail should never be positioned under High Friction or roller type chain links. If the chain includes High Friction or roller links, the rail should run under the acetal center links only. This will reduce the chance of the rail coming into contact with High Friction or roller links — a situation that can cause excessive drag and premature failure of the conveyor.

If it becomes necessary to cut and trim a center support rail, hold the trailing end in position and make a mark at the intended cut location (refer to *Figure 8*). Use pruning shears to cut the center support rail at the mark. Chamfer the end of the rail and install the rail, as illustrated and described above.

STEP 4 — Install and Inspect Wearstrips

The wearstrip is one of the most important features of Span Tech's Designer System® conveyors. The conveyor chain is designed with legs on the outer links that hook around the lips of the conveyor side frame. The lips of the side frame have a Spanlon wearstrip fitted over them. The conveyor chain contacts this wearstrip, resulting in smooth chain travel, reduced load on the motor, and the prevention of damage caused by the chain directly contacting the metal side frame. Special care must be taken when installing the wearstrips.

NOTICE

Failure to read and follow these instructions could result in damage to the conveyor system.

Connecting Pre-Cut Wearstrips

If the conveyor system being installed has been field broken for shipping purposes, the wearstrips at the break locations have already been properly trimmed according to the direction of chain flow and the environment in which the system will operate. In this case, simply push the wearstrips into place on the frame lips and proceed to the applicable wearstrip installation procedures, on *page 24*.

Before Cutting Wearstrips (if necessary)

Four factors must be considered before making cuts: **temperature**, **cut angle**, **cut direction**, and **cut location**.

TEMPERATURE: The temperature at which the wearstrip is installed in a conveyor, as well as the temperature at which the conveyor will normally be operating, both need to be considered before the wearstrips are cut and trimmed. Cooler operating temperatures cause the wearstrips to contract or become shorter. Warmer operating temperatures cause the wearstrips to expand or become longer.

At Span Tech, conveyors are pre-assembled at an average room temperature of about 70° F (21° C). If the conveyor is installed in a room with an average temperature of 20° F (- 6.7° C), the wearstrip will naturally contract. When the wearstrip contracts, the gap between adjacent pieces gets wider. If the gap gets too wide, the conveyor's chain could derail from the system. On the other hand, if the conveyor is installed in a room with an average temperature of 100° F (37.8° C), the wearstrips will expand, causing the gap between adjacent pieces to get smaller. A wearstrip could even start to overlap onto the next, possibly resulting in damage to the conveyor.

The gap between adjacent wearstrips should be maintained at or very near 1/4" (6.35mm). The Wearstrip Gap Chart (*below*) indicates the gap that should be left between adjacent wearstrips at various installation temperatures, as compared to various temperatures at which the conveyor will operate. *Example:* If the wearstrips are installed in a conveyor at a room temperature of 60° F (15.5° C), but the conveyor will normally be operating in a 100° F (37.8° C) environment, you should leave a 3/8" (9.5mm) gap between wearstrips as they are installed.

WEARSTRIP GAP CHART

	NORMAL OPERATING TEMPERATURE						
	0° – 20°F	21° – 40°F	41° – 60°F	61° – 80°F	81° – 100°F	101° – 120°F	
	-17.8° – -6.7°C	-6.1° – 4.4°C	5.0° – 15.5°C	16.1° – 26.7°C	27.2° – 37.8°C	38.3° – 48.9°C	
INSTALLATION TEMPERATURE	0° – 20°F -17.8° – -6.7°C	21° – 40°F -6.1° – 4.4°C	41° – 60°F 5.0° – 15.5°C	61° – 80°F 16.1° – 26.7°C	81° – 100°F 27.2° – 37.8°C	101° – 120°F 38.3° – 48.9°C	
	1/4"	5/16"	7/16"	1/2"	9/16"	5/8"	
	6.4mm	7.9mm	11.1mm	12.7mm	14.3mm	15.9mm	
	3/16"	1/4"	5/16"	3/8"	1/2"	9/16"	
	4.8mm	6.4mm	7.9mm	9.5mm	12.7mm	14.3mm	
	1/8"	3/16"	1/4"	5/16"	3/8"	1/2"	
	3.2mm	4.8mm	6.4mm	7.9mm	9.5mm	12.7mm	
	1/16"	1/8"	3/16"	1/4"	5/16"	3/8"	
	1.6mm	3.2mm	4.8mm	6.4mm	7.9mm	9.5mm	
	0"	1/16"	1/8"	3/16"	1/4"	5/16"	
	0mm	1.6mm	3.2mm	4.8mm	6.4mm	7.9mm	
	0"	0"	1/16"	1/8"	3/16"	1/4"	
	0mm	0mm	1.6mm	3.2mm	4.8mm	6.4mm	

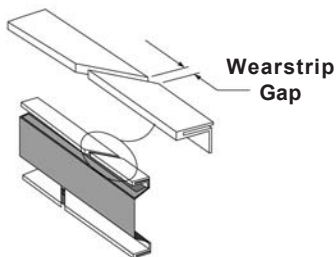

STEP 4 — Install and Inspect Wearstrips (continued)

CUT ANGLE: The ends of adjoining wearstrip sections should be trimmed at 60° angles, as shown in *Figure 10*. This angle, in conjunction with the direction in which the angles are cut (discussed below), allows the chain to travel smoothly over the wearstrip joint.

CUT DIRECTION: The direction in which the conveyor chain will travel dictates the direction at which the wearstrip angles will be cut. *Figure 10* shows the correct angles in relation to the direction of chain flow. When making cuts, keep in mind that the conveyor chain runs in the opposite direction on the underside of the frame.

NOTICE

For bi-directional conveyors, the wearstrips should be cut “square” and positioned end-to-end (touching).

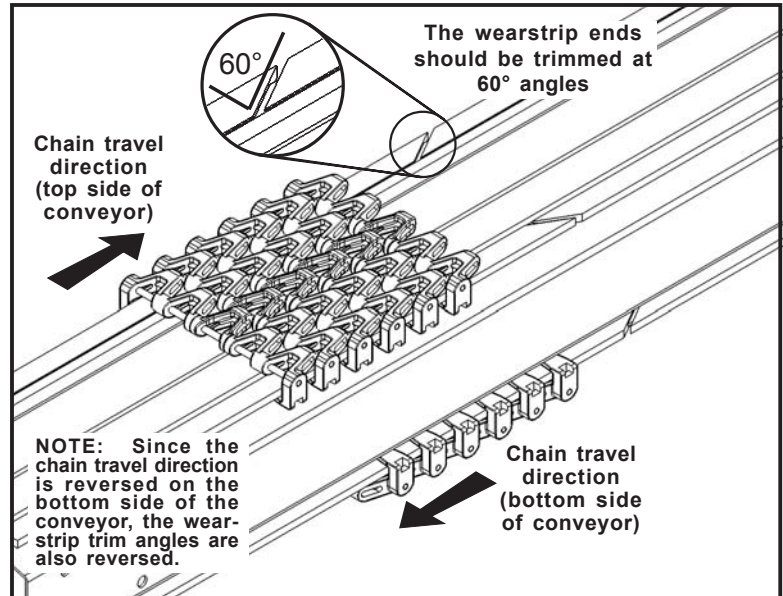

Figure 10: Overview of Wearstrip assembly

NOTICE

Failure to cut the wearstrips at the proper angle, direction, and gap may cause the chain to catch at the wearstrip joint and possibly derail from the conveyor.

CUT LOCATION: Wearstrip joints and conveyor bed section joints should never be located at the same spot (*Figure 11*). The wearstrip should span across the side frame joint, and extend beyond the side frame joint by at least 10” (254mm). Always be sure the wearstrip is firmly seated against the side frame as shown (*Figure 12*), especially in horizontal and vertical bend locations.

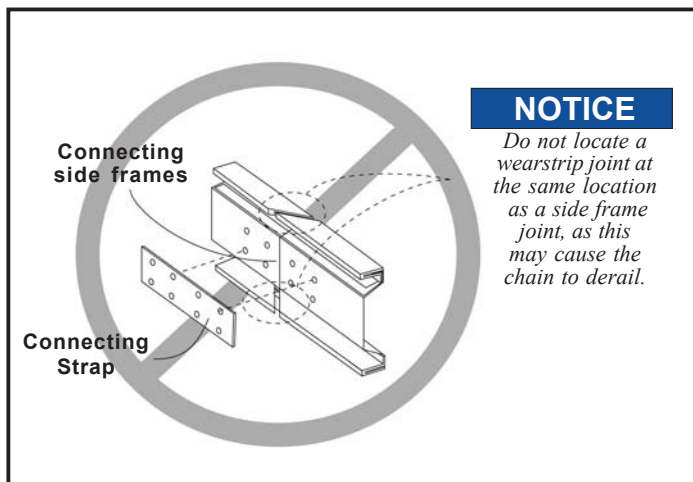

Figure 11: Do not locate wearstrip joint at bed section joint

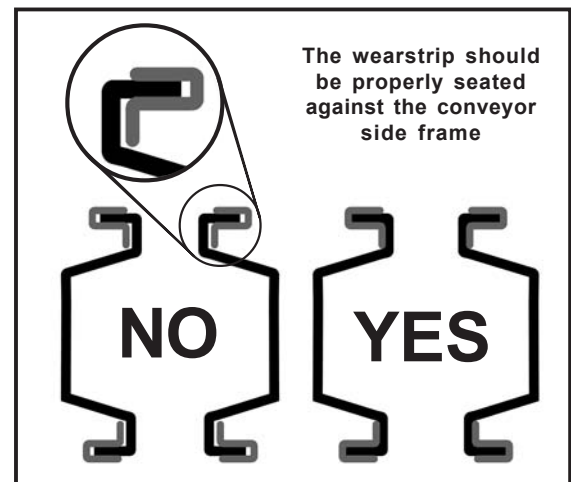

Figure 12: Ensure wearstrip is correctly seated

STEP 4 — Install and Inspect Wearstrips (continued)

Installing Wearstrips

- Cut a 60° angle on the leading edge of the wearstrip (*Figure 13*). Make the first cut a little overlong, then trim as needed. This will help to ensure that the wearstrip is not cut too short on the first cut.

NOTICE

Ensure that the angles are cut correctly with regard to the direction of chain flow. Refer to **Figure 10** on previous page.

- Slide the wearstrip into the conveyor side frame (*Figure 14*).

For straight sections, each wearstrip section will need to be approximately two feet long. Both ends of each wearstrip section must be cut at a 60° angle. The correct gap must be provided between consecutive pieces of wearstrip; refer to the Wearstrip Gap Chart and other information on *page 22*.

- Once the wearstrip is properly seated against the side frame, use a flashlight or other portable light to locate the side frame's mounting hole (*Figure 15*).
- Drill a 13/64" (5.5mm) hole through the leading edge of the wearstrip (*Figure 15*).
- Load one of the supplied plastic rivets into the Rivet Insertion Tool (*Figure 16*), and install the rivet to attach the wearstrip to the side frame (*Figure 17*). Only one rivet is required for each two-foot section of wearstrip.
- Ensure that the rivet is fully installed and is firmly against the surface of the wearstrip.



Figure 13: Cut wearstrip at 60° angle



Figure 14: Slide wearstrip into side frame

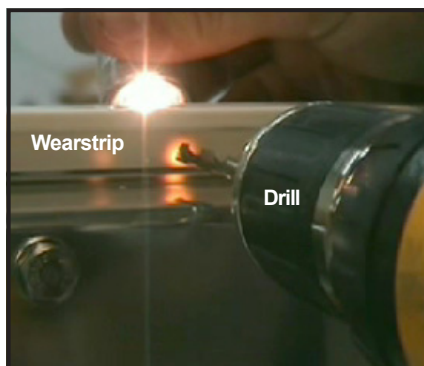

Figure 15: Use light to locate hole; drill hole in wearstrip

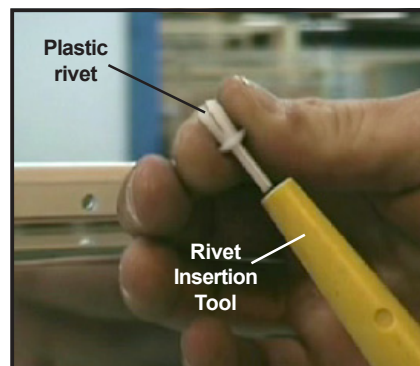

Figure 16: Load plastic rivet into Rivet Insertion Tool

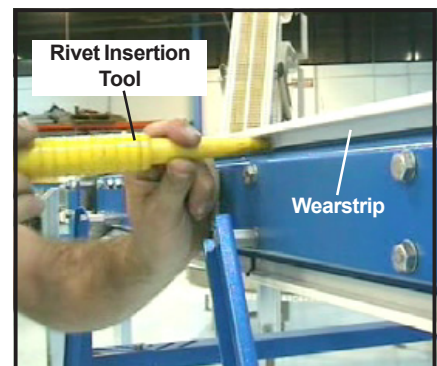

Figure 17: Install rivet to secure wearstrip

STEP 5 — Install Guide Rail and Return Chain Support Rail

If the conveyor system being assembled includes guide rails and/or return chain support rails, a continuous and smooth rail connection is required.

Guide Rail

Guide rail is designed to guide the product as it travels along the conveyor chain. At field-break locations, connect the rails with a splice sleeve (*Figure 18*). This sleeve envelops the metal backing of both ends of the rails. To remove a guide rail after the splice sleeve has been installed, slide the sleeve along the rail as necessary.

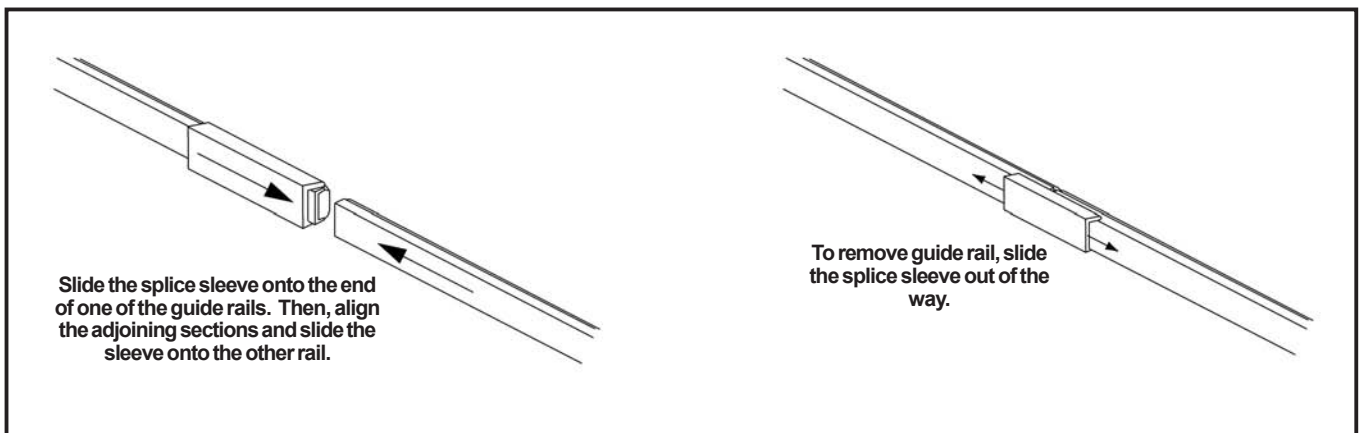

Figure 18: Installing and removing splice sleeve

Chamfering the leading edge of the guide rail at each splice location (*Figure 19*) will lessen the possibility of product hang-ups.

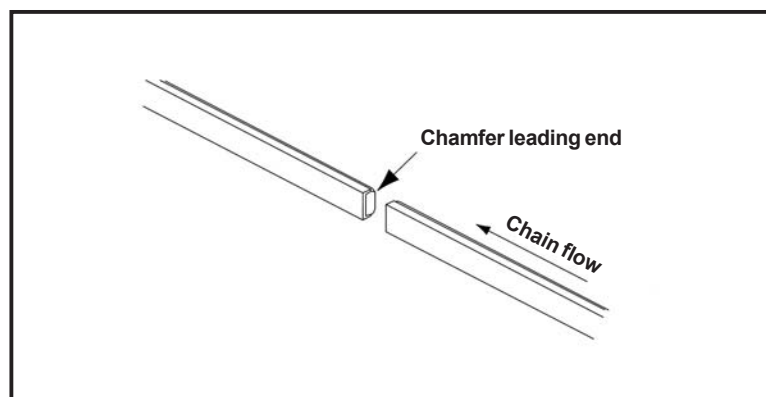

Figure 19: Chamfer Guide Rail's leading edge

STEP 5 — Install Guide Rail and Return Chain Support Rail (continued)

Return Chain Support Rail

Return chain support rail (*Figure 20*) is used on conveyors more than 24" (609mm) wide. It supports the weight of the return chain (on the bottom side of the conveyor) to prevent it from sagging. When return chain support rail is required, there will be at least two return chain support crossbars on the conveyor. Any splices in the return rail should be located as close to a support as possible. Field break locations are connected in the same manner as the guide rail. The illustration in *Figure 20* shows how standard return chain support rails are assembled.

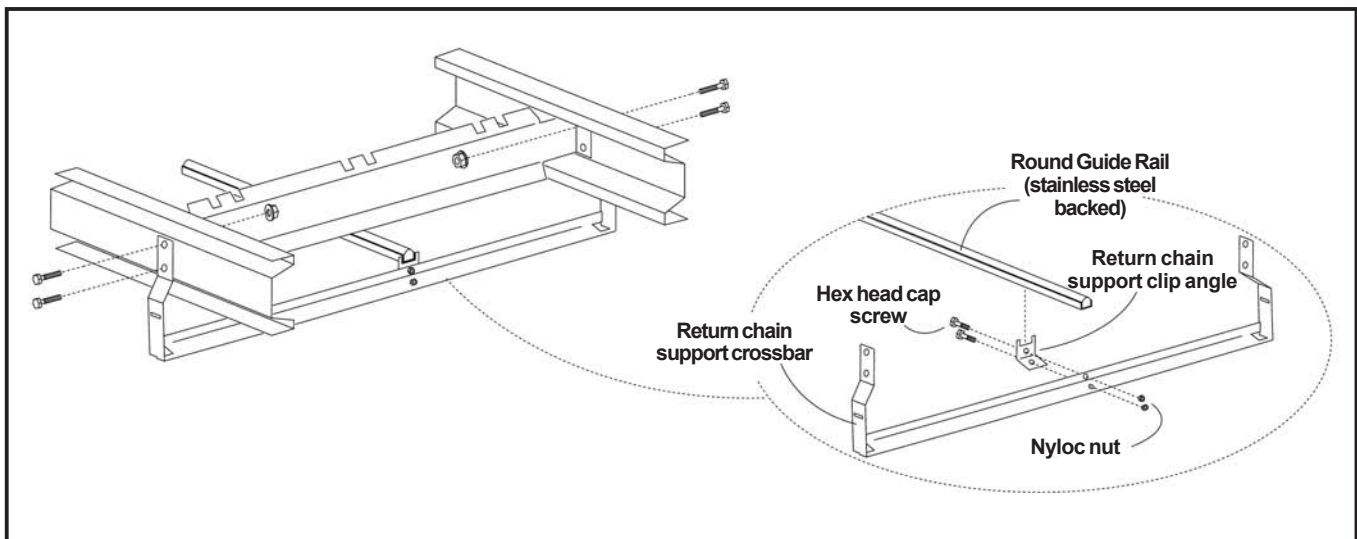

Figure 20: Overview of Return Chain Support Rail assembly

STEP 6 — Install Support Structures

NOTICE

To avoid binding and possible damage to the conveyor system, do not tighten or anchor any support structure to the floor until the entire conveyor system has been assembled and properly positioned.

The specific procedure for the installation of the support structure depends upon the type of structure specified for the conveyor being installed. Two common support styles are shown below (Figure 21). The distance between support structures should never exceed 12 ft (3.66m).

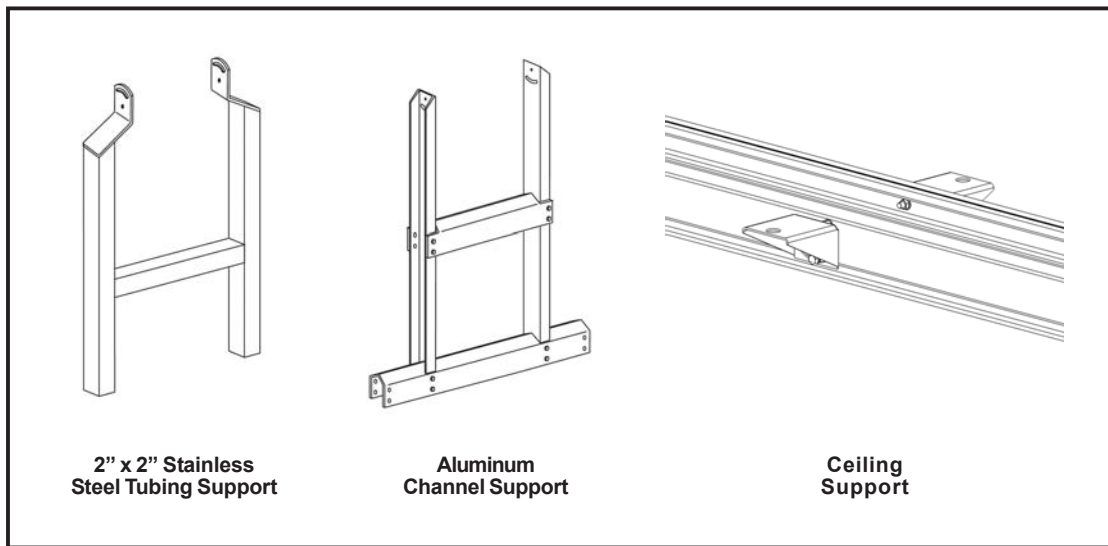

Figure 21: Support Structure styles

The support structure units, regardless of style, will be bolted to the conveyor bed's framing at the crossbar locations. Prior to shipping, matching pairs of numbered "Support" labels (Figure 22) have been affixed to the equipment as an assembly aid. One label is affixed to each support structure; the corresponding numbered label is affixed to the conveyor side frame to indicate the correct attachment location for the support.

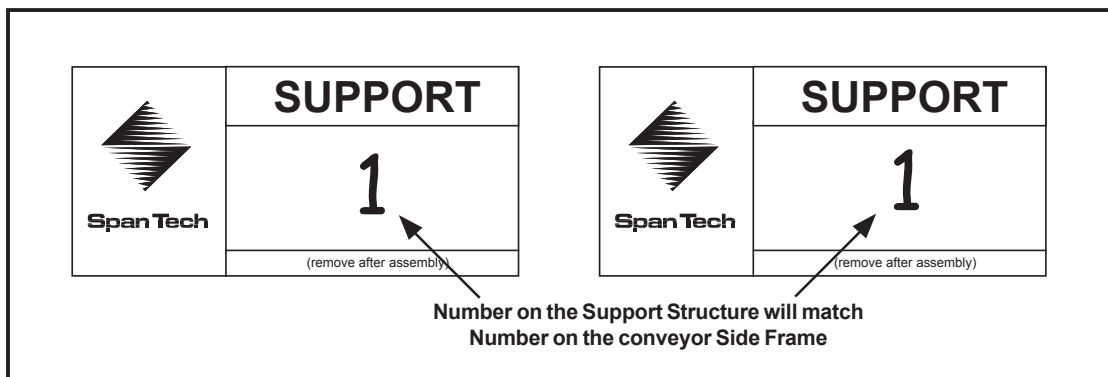

Figure 22: "Support" labels

STEP 6 — Install Support Structures (continued)

Upon completion of support structure installation, ensure that the conveyor system is level. Any minor elevation adjustments that may be required (usually due to an uneven floor) can be accomplished using the conveyor support structure's adjustable feet. *Figure 23* illustrates some examples of various styles of adjustable feet. If greater elevation adjustments are required, it may be necessary to actually shorten or lengthen the support legs.

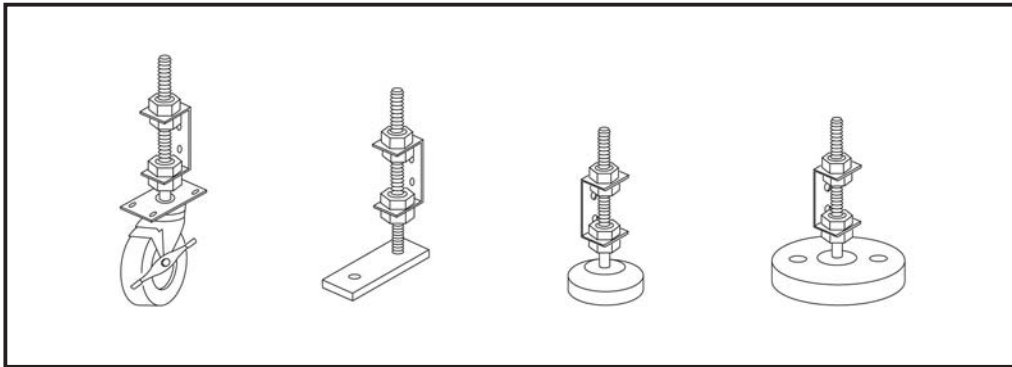

Figure 23: Types of adjustable feet

Sway Braces

The amount of sway bracing necessary will depend upon the design of the specific conveyor system being installed. The location of the sway braces can be found on the schematic (plan view). The symbol shown in *Figure 24* indicates the location of a diagonal sway brace. All sway braces, and the hardware required to attach them to the support structures, are supplied with the system. One end of each sway brace is bolted to the conveyor side frame; the other end is bolted to a support leg.

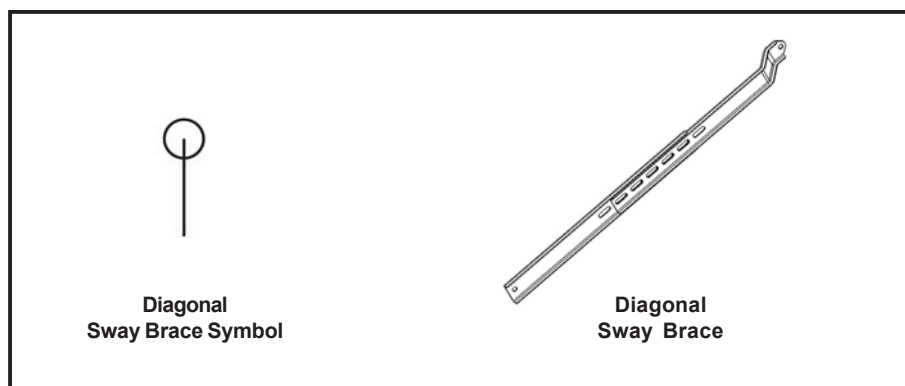

Figure 24: Sway Brace symbol and illustration

STEP 7 — Install Conveyor Chain

General Notes Regarding Conveyor Chain

The chain has been assembled at Span Tech according to specification. To maximize ease of handling, the chain has been packed in lengths of no more than 15 ft (4.57m).

NOTICE

Do not unpack the chain until you are ready to install it, to avoid the possibility of exposing the chain to damaging contaminants.

Your Span Tech conveyor will typically be equipped with MonoSpan[®], MultiSpan[®], or MaxiSpan[®] conveyor chain. The type of chain depends upon the application for which the conveyor system has been specified. Before attempting to install a Span Tech conveyor chain for the first time, it is recommended that you take a few moments to become familiar with the chain links and how they interact with each other. Illustrations of the three basic chain types are shown below (*Figures 25, 26, 27*). Use the information in the illustrations to determine the chain orientation and direction of chain flow.

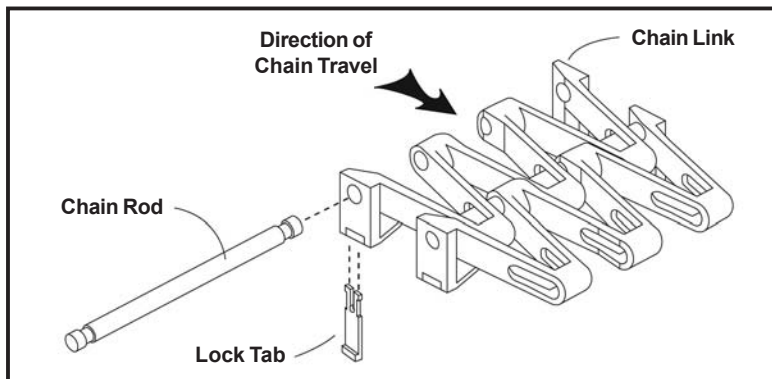

Figure 25: MonoSpan[®] chain assembly

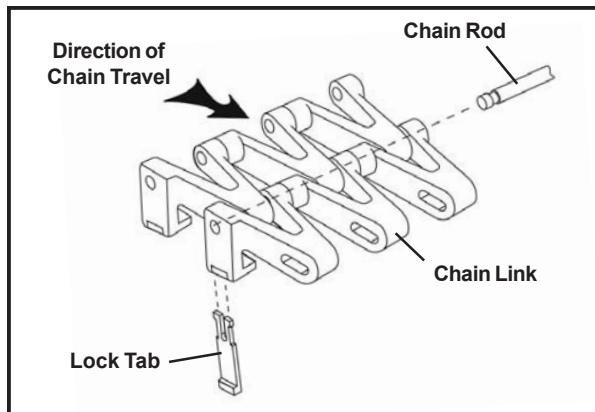

Figure 26: MultiSpan[®] chain assembly

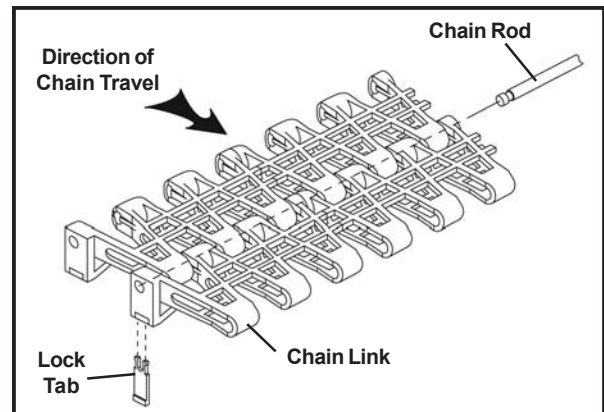

Figure 27: MaxiSpan[®] chain assembly

Chains are constructed of interconnecting links. The links are installed on chain rods that have been cut according to the specified chain width. The rods are held in place by lock tabs that fit into slots in the chain's side links. The illustrations above show the relationship of the various chain components.

NOTICE

The chain, like all of the conveyor components, must be kept clean during installation to ensure proper operation. Dust and environmental debris can damage the chain and void the warranty.

STEP 7 — Install Conveyor Chain (continued)

Chain Installation

- Before installing the chain, check for any pre-installed accessories on the conveyor (guide rails, etc.) that could make it difficult to load the chain, and remove them if necessary. It may also be necessary to disengage the gearmotor from the drive shaft so that the chain will feed around the drive sprockets (refer to STEP 8 – Installing/Removing Gearmotors).
- Start at the “Idler” end of the conveyor when installing the chain (*Figure 28*).
- Pull the unanchored ends of the wearstrip sections nearest the idler away from the frame. This will expose both of the side frame lips on the top side of the conveyor, and provide enough clearance to install the chain.
- Ensuring that you have the chain right side up and in the correct direction of flow, start feeding the chain (from the chain’s leading end) onto the exposed lips of the side frame. Work the tab legs on each side of the chain down onto the lips of the side frame by shifting the chain from side-to-side.
- As the chain legs enclose the side frame lips, push the chain forward onto the wearstrip. If working with a wide chain, this process may require two people. Chain installation should not require excessive force.

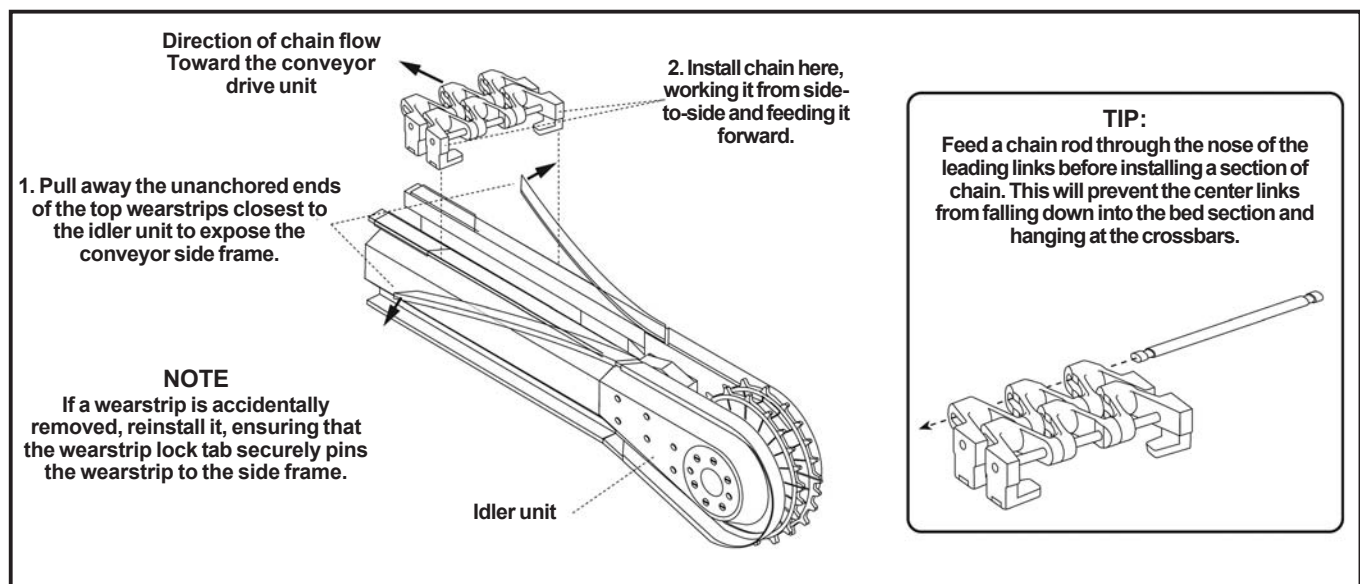

Figure 28: Chain installation

- If the first roll of chain does not reach the drive end of the conveyor, push it ahead and load another roll of chain. After the second roll of chain has been loaded, join the two sections with a chain rod and install the chain lock tabs (refer to *Figures 31 and 32*, on page 31).
- Continue loading sections of chain until the leading end reaches the drive.
- When the chain has reached the drive end of the conveyor, engage the chain with the drive sprockets (*Figures 29 and 30*, on page 31). Ensure that the chain links and sprocket teeth are aligned across the chain width.

For MonoSpan® or MultiSpan® chains:

- The sprocket tooth should engage the chain directly behind a connecting rod.

For MaxiSpan® chains:

- The larger sprocket tooth should engage the chain directly behind a connecting rod.

STEP 7 — Install Conveyor Chain (continued)

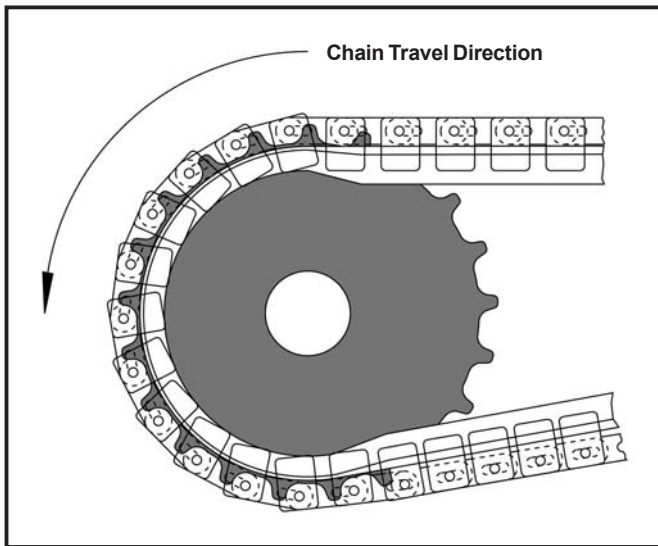

Figure 29: Sprocket engaging MonoSpan® or MultiSpan® chain

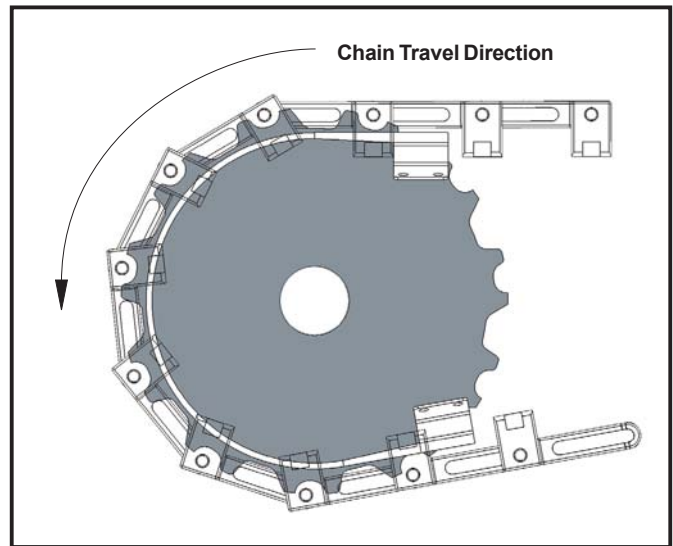

Figure 30: Sprocket engaging MaxiSpan® chain

- Feed the chain around the drive by either (A) pulling the end of the chain around, or (B) rotating the drive shaft by hand. DO NOT push the chain into the drive sprocket(s) as the compressed chain will not engage the sprocket(s) properly. If done correctly, the chain will feed smoothly.
- Continue to load and join all of the remaining sections of chain.
- Push in the wearstrips that were pulled out.
- Feed the chain around the idler sprocket(s), then join the ends of the chain to complete the loop, as follows:
 - Insert the chain rod on one side, and reconnect each link as you push the rod through (Figure 31).
 - If connecting High Friction chain, it may help to use a small amount of soapy water on the chain rod so that it slides through more easily.
 - Once the rod is in place, insert the lock tabs into the side links (Figure 32). The lock tabs must snap up into the chain link. The lock tabs will slide easily into the cavity of the chain if they are inserted at a slight angle.

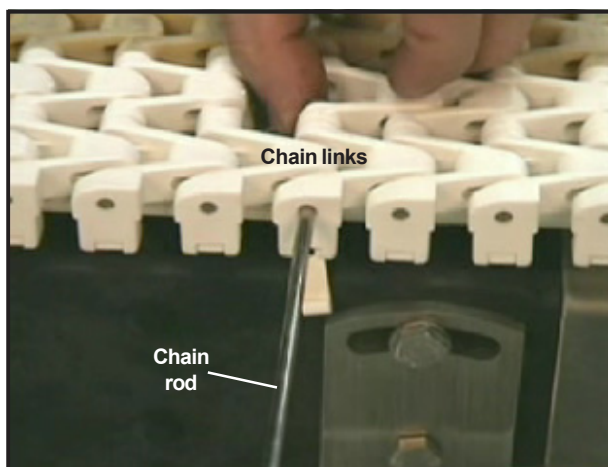

Figure 31: Insert chain rod through links

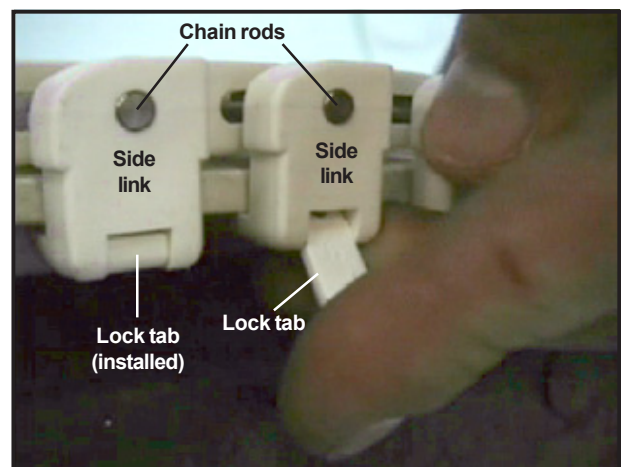

Figure 32: Insert lock tab

STEP 7 — Install Conveyor Chain (continued)

⚠ WARNING

Remove all foreign objects, such as tools or hardware, from the chain and conveyor bed sections before energizing or operating the conveyor. Failure to comply could result in serious injury or equipment damage.

Chain Slack

If the chain slack is correct, you should be able to pull three rows of links together with your thumb and forefinger, just after the drive unit on the return side (*Figure 33*). If you cannot pull three rows together, the chain is too tight. If you can pull more than three rows together, the chain is too loose.

Chain slack is adjusted by adding or removing rows of links, as follows:

- Using a small flat screwdriver, break the chain loop by removing the lock tab at each end of a chain rod.
- Remove the chain rod.
- Push the chain apart, then remove the wearstrip sections as described in the “Chain installation” procedure (*page 30*).
- Add or remove a row of chain links as required.
- Replace the wearstrips.
- Reconnect the chain loop.
- Repeat the above process as necessary until chain slack is correct. It may be necessary to remove chain slack after the system has been started at least once.

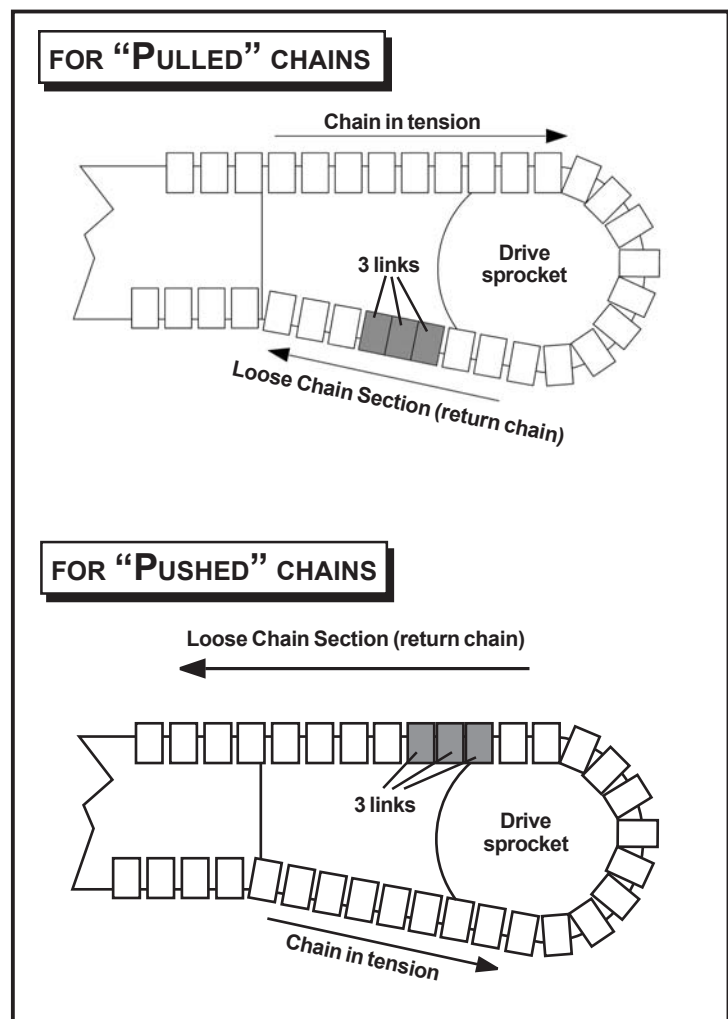

Figure 33: Chain slack illustration for “Pulled” and “Pushed” chains

STEP 8 — Install / Remove Gearmotor

Span Tech conveyor systems are typically supplied with SEW Eurodrive gearmotors. General instructions concerning the installation and removal of SEW Eurodrive gearmotors are provided in this section.

⚠ WARNING

Starting devices, prime movers, and powered accessories should be locked and tagged following OSHA regulations before assembly, maintenance, or repair tasks are performed on any conveyor system. Only trained and qualified personnel who are aware of all safety hazards and how to avoid them should be allowed to perform maintenance procedures. Failure to comply could result in serious injury or death, or equipment damage.

Gearmotors are heavy! Two persons should participate in any gearmotor removal or installation. Failure to comply could result in serious injury or equipment damage.

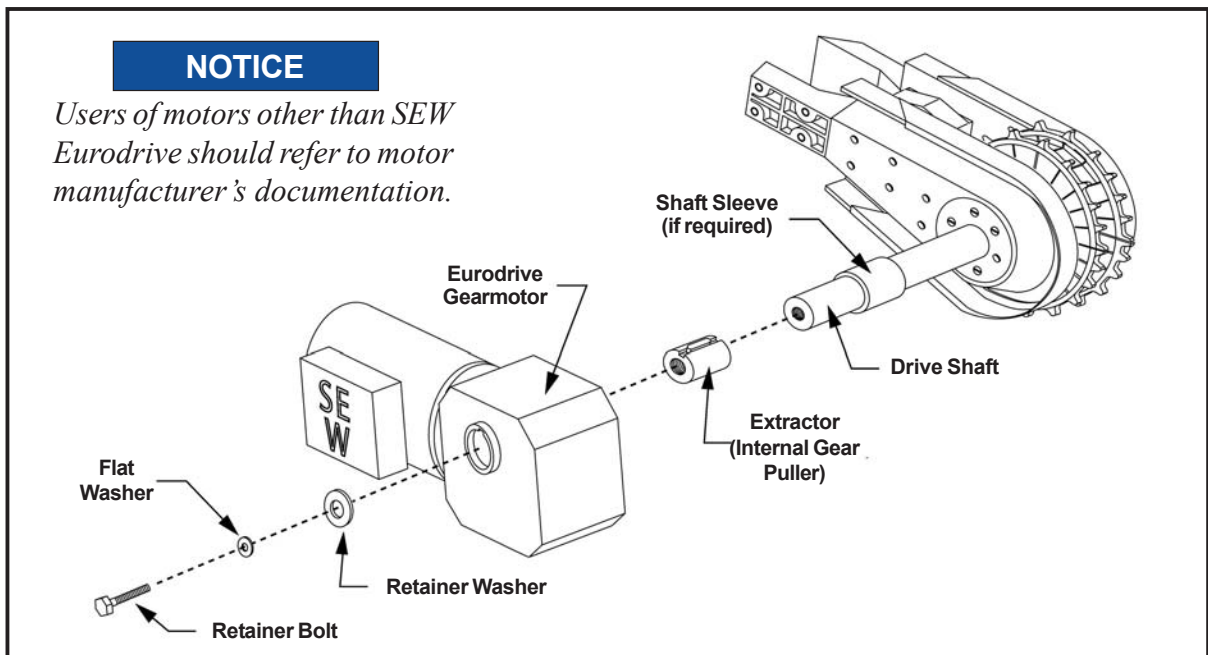

Figure 34: SEW Eurodrive gearmotor assembly

Eurodrive Gearmotor Installation

- Assemble the components as follows; refer to the exploded view in *Figure 34*.
 - Apply a liberal amount of anti-seize compound to the outside of the drive shaft (*Figure 35*).
 - Verify that the key is in place on the drive shaft (*Figure 35*).

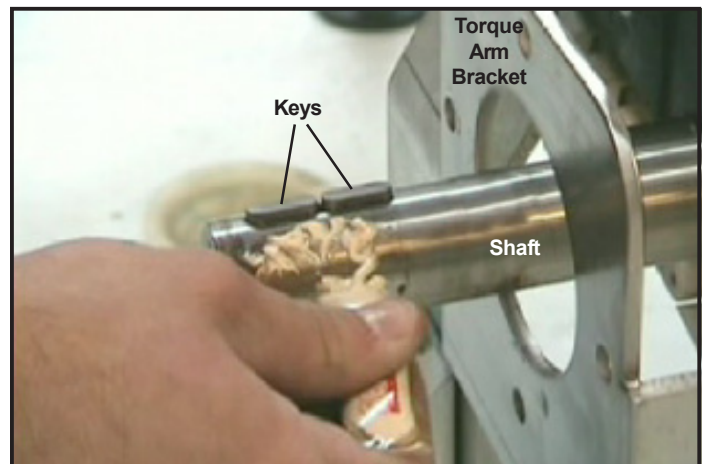

Figure 35: Apply anti-seize compound

STEP 8 — Install / Remove Gearmotor (continued)

- Insert the extractor into the same end of the gearbox into which the drive shaft will be inserted (*Figure 36*). The extractor bolt should “bottom out” on the retaining ring in the gearbox.
- Gently slide the gearbox onto the drive shaft, and align the keyways together. The gearbox should slide all the way to the torque arm bracket (*Figure 37*).
- Install and tighten the retaining bolt on the end of the shaft (*Figure 38*).
- Install and tighten the four bolts that hold the gearmotor to the torque arm bracket (*Figure 39*).
- Install the plastic end cap that protects the end of the drive shaft.

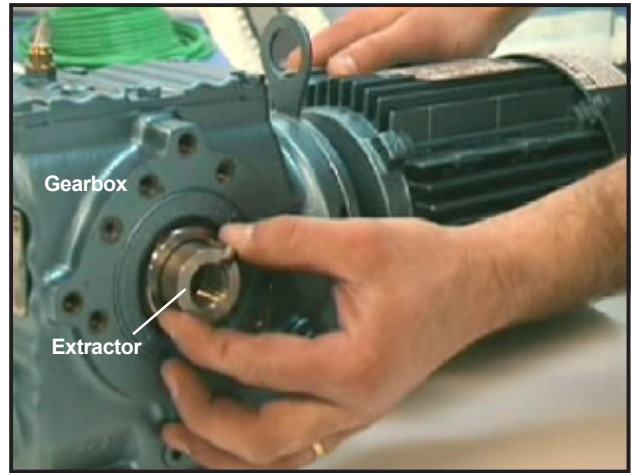

Figure 36: Insert extractor

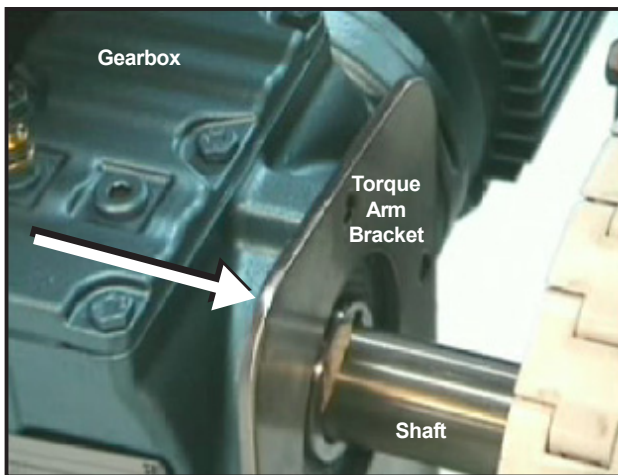

Figure 37: Slide gearbox onto drive shaft

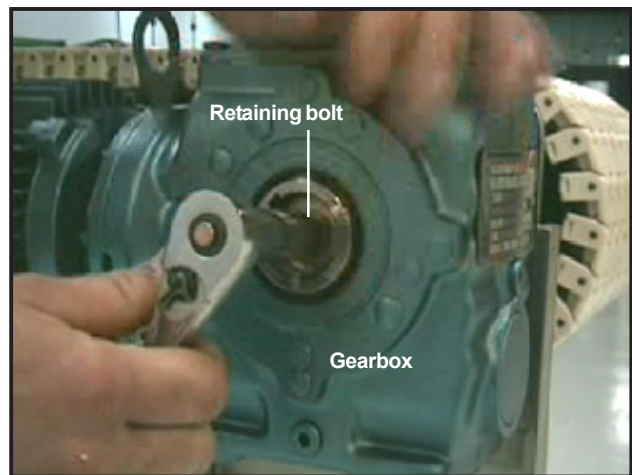

Figure 38: Install and tighten retaining bolt

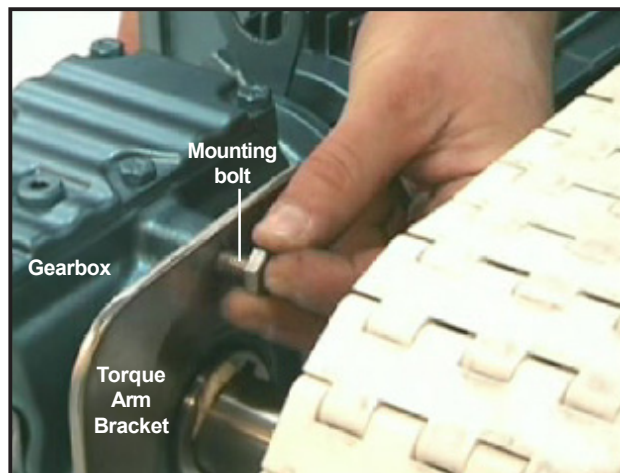

Figure 39: Install and tighten four mounting bolts

STEP 8 — Install / Remove Gearmotor (continued)

Eurodrive Gearmotor Removal

- Remove the plastic end cap from the gearbox to expose the end of the drive shaft (*Figure 40*).
- Using a 13mm wrench, remove the four bolts that hold the gearmotor to the torque arm bracket (*Figure 41*).
- Using a 1/2" (13mm) socket, remove the retaining bolt from the end of the shaft (*Figure 42*).
- If the gearbox will not slide off, insert extractor bolt into the gearbox extractor, located at the end of the drive shaft (*Figure 43*).
- Continue turning this threaded rod until the gearbox is driven off the drive shaft.



Figure 40: Remove end cap

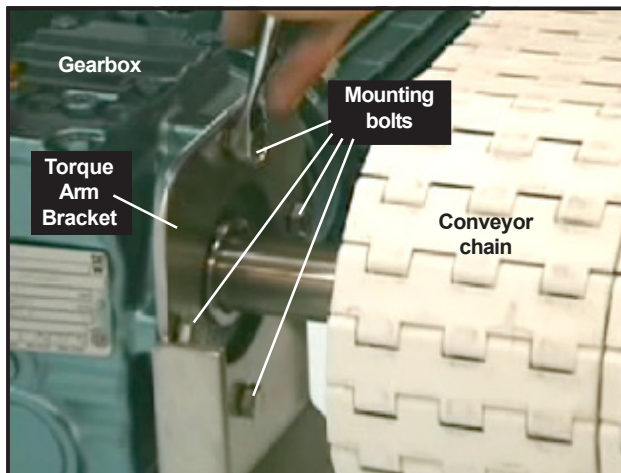

Figure 41: Remove four mounting bolts

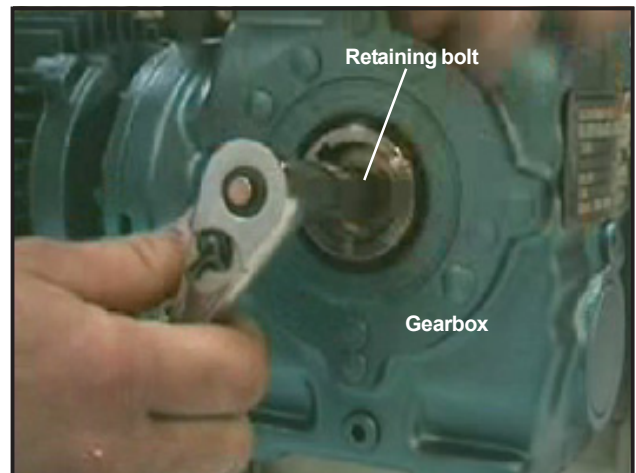

Figure 42: Remove retaining bolt

MOTOR SIZE	EXTRACTOR (METRIC)	EXTRACTOR (ENGLISH)
WA20	M12 x 1.75 x 75	1/2-13 x 3"
WA30	M12 x 1.75 x 75	1/2-13 x 3"
SA37	M12 x 1.75 x 140	1/2-13 x 5-1/2"
SA47	M20 x 2.5 x 150	3/4-10 x 6"
SA57	M20 x 2.5 x 150	3/4-10 x 6"
SA67	M20 x 2.5 x 190	3/4-10 x 7-1/2"

Table A: Extractor Bolt sizes (NOTE: motor sizes refer to SEW Eurodrive motors)

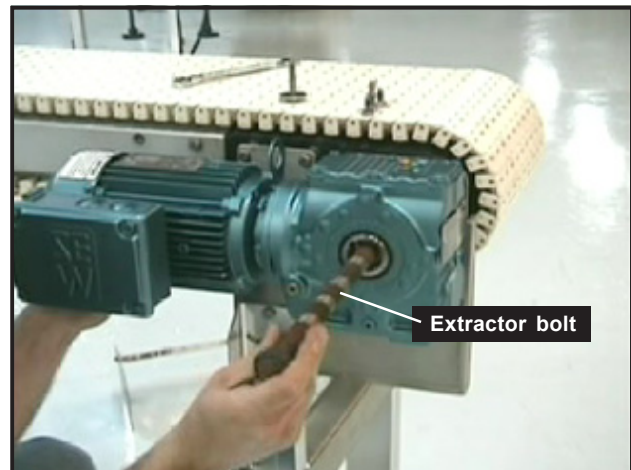

Figure 43: Insert extractor bolt to drive gearbox off shaft

STEP 8 — Install / Remove Gearmotor (continued)

For Keyed Drives: see *Figure 44*

NOTICE

Be sure that the key is the correct size, and is well-seated into the drive shaft keyway and the gearbox keyway.

Be sure that the drive shaft runs all the way through the gearbox housing.

Be sure that the key is correctly positioned.

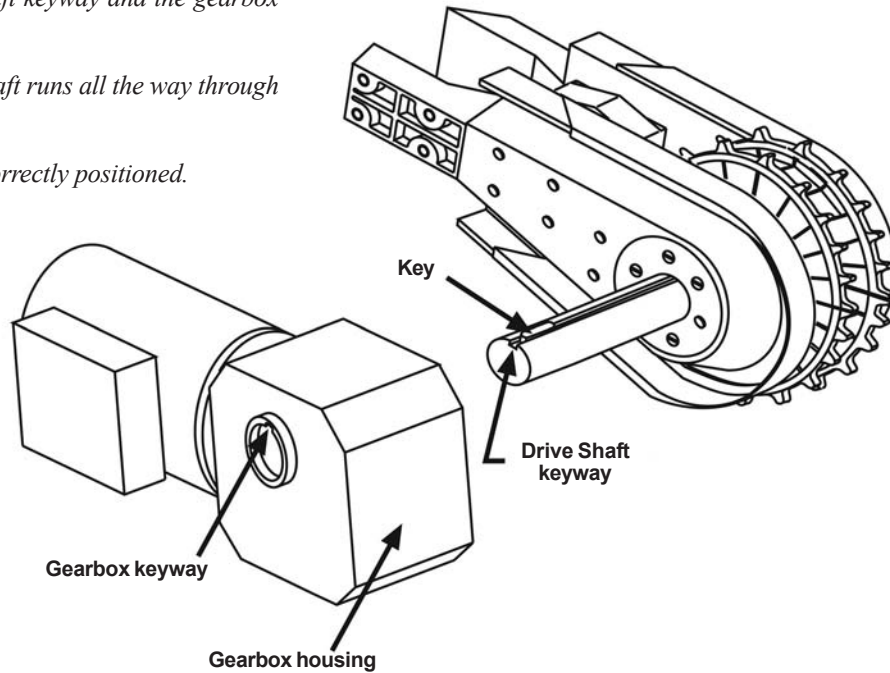

Figure 44: Illustration of keyed drive assembly

STEP 8 — Install / Remove Gearmotor (continued)

Proper alignment of gearbox on drive shaft for remote drives: see *Figure 45*

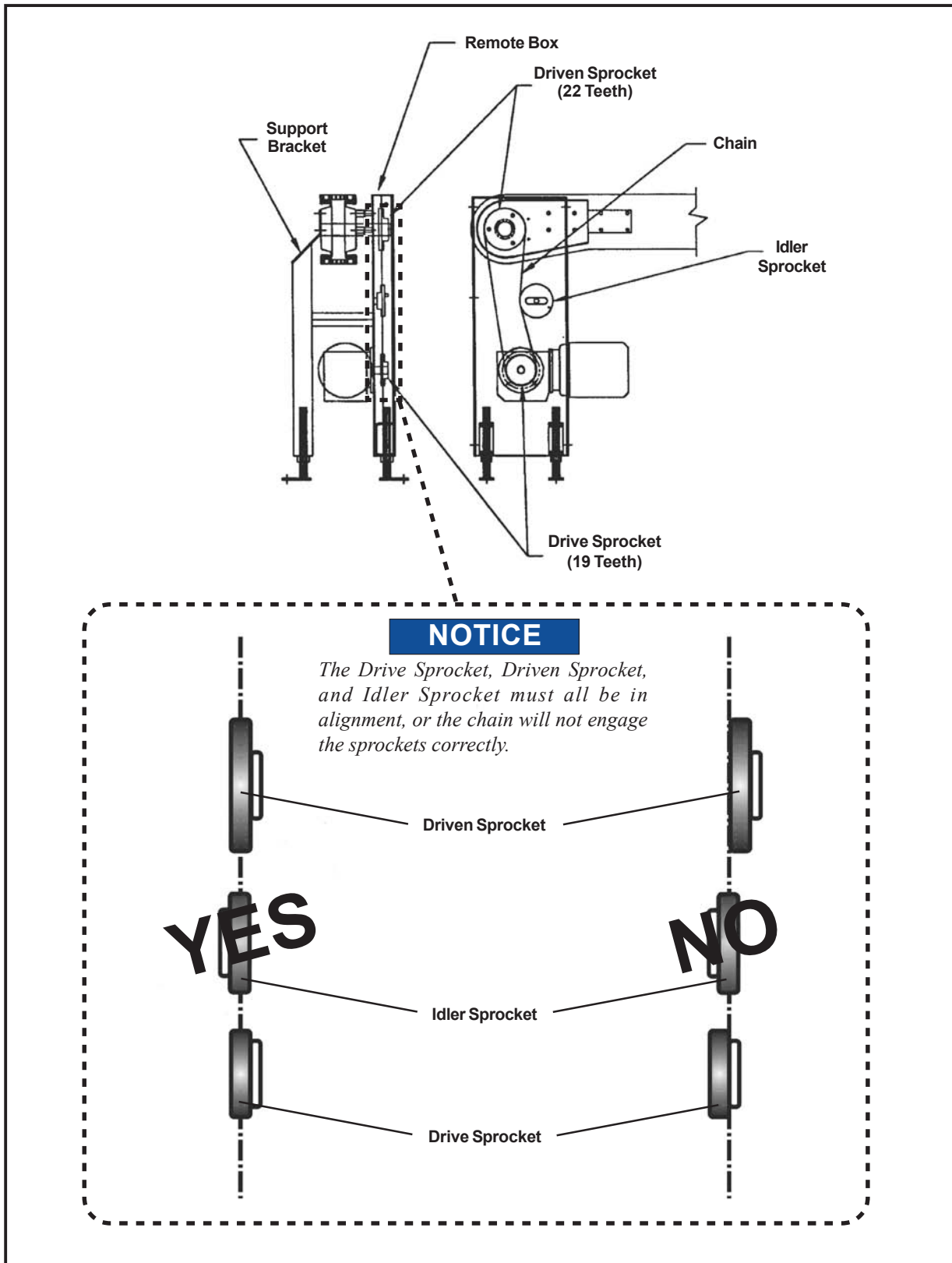

Figure 45: Remote drive alignment illustration

STEP 8 — Install / Remove Gearmotor (continued)

Gearbox Mounting Positions

A gearbox (garmotor) can be mounted in any of several orientations with respect to the conveyor. Always refer to specific job prints for the proper mounting orientation. The following photographs and illustrations (*Figures 46, 47, 48*) show examples of different mounting positions.

NOTICE

The gearmotor is only allowed to be installed in the mounting position indicated by the job-specific drawings provided with the conveyor. The oil checking and drain screws, and the breather valves, must be freely accessible. Also check that the oil fill is as specified for the mounting position. SEW-Eurodrive supplies gear units filled with the required oil volume, and with the breather valve installed and activated according to the particular mounting position. Adjust the lubricant fill volumes and the position of the breather valve accordingly, in the event of a change of mounting position.

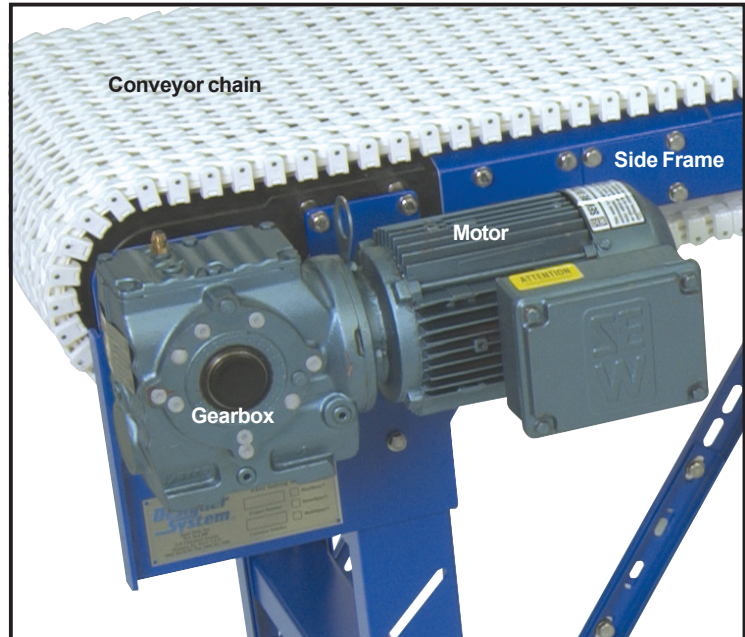

Figure 46: Hollow shaft gearmotor, horizontally mounted

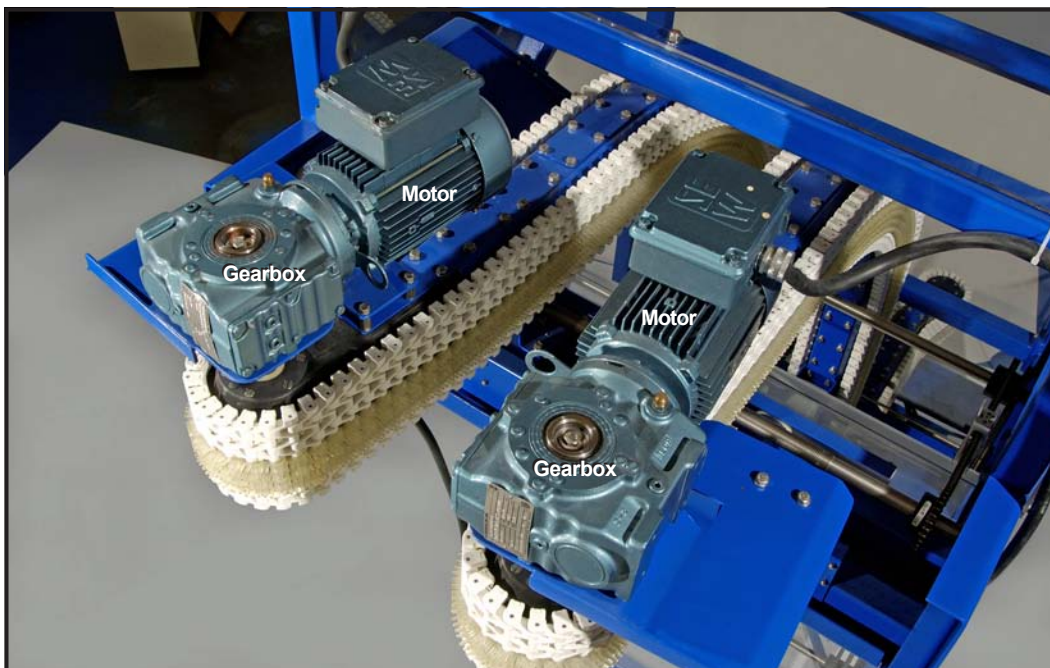

Figure 47: Hollow shaft gearmotors, mounted to vertical drive shafts (Wedge conveyor)

STEP 8 — Install / Remove Gearmotor (continued)

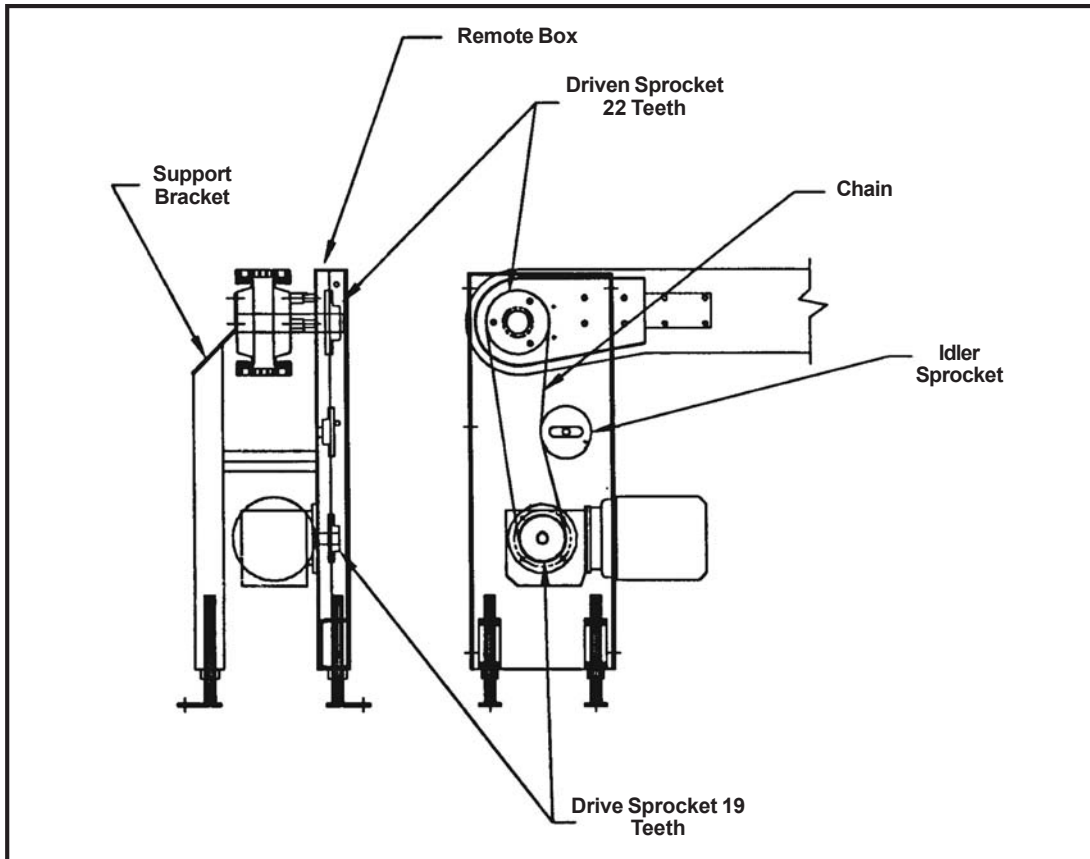

Figure 48: Remote gearbox mounting position (typical)

Gearbox Breather Valve (Vent Plug) Location

A breather valve (*Figure 49*) should always be installed in the provided hole *in the upward face* of the gearbox.

NOTICE

The gearbox will leak oil if the breather valve is not installed, or if it is installed in an incorrect location.



Figure 49: Breather Valve

STEP 9 — Install Transfer Bridge: Gravity Roller Transfer

Gravity Roller Transfer Bridge Installation: see *Figure 50*

- Install the roller bridge assembly, so that the bridge assembly rods rest in the notches in the side plate.
- Remove the screw that attaches the safety cable to the side plate.
- Insert the screw through the safety cable eyelet, and reinstall it in its original location.
- Repeat above Steps for the other side of the transfer.

NOTE

The non-rigid mounting design allows the bridge to pop out in the event of a product jam, preventing damage to the equipment. This design is also a safety feature, protecting employees from harm should they become caught between the transfer rollers and the conveyor.

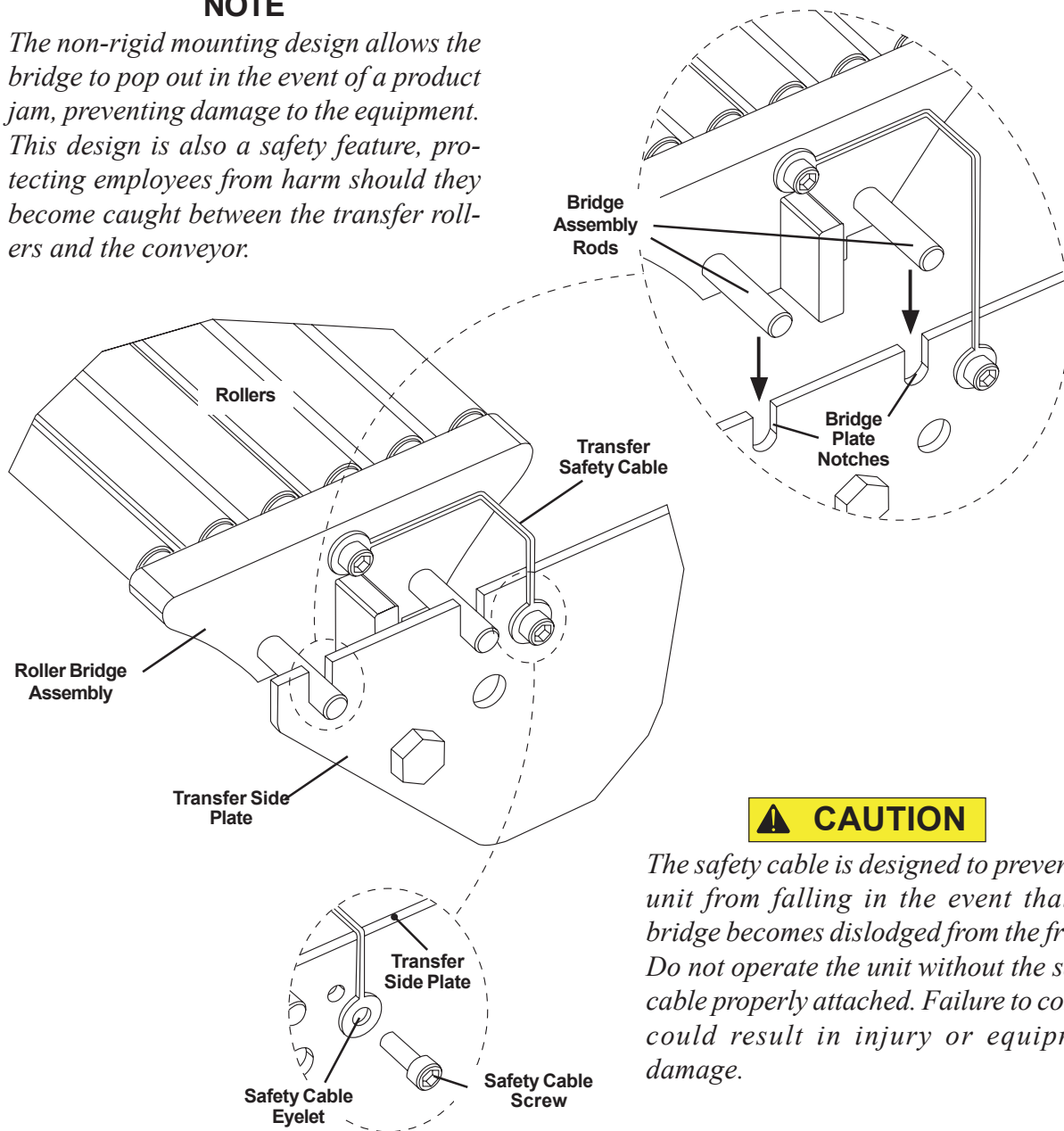
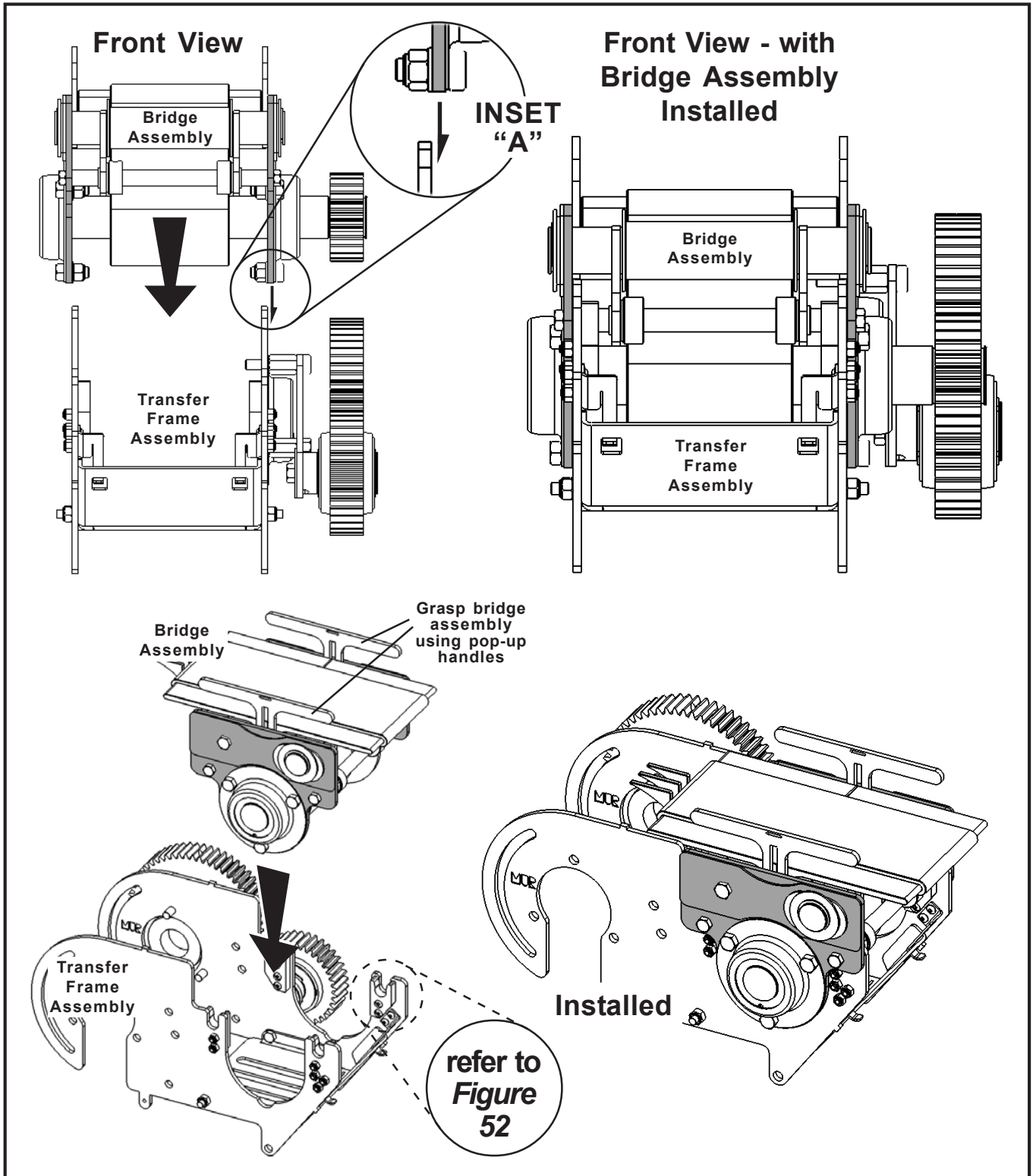

Figure 50: Transfer Bridge assembly illustration - Gravity Roller Transfer

STEP 10 — Install Transfer Bridge: MicroSpan Transfer

MicroSpan Transfer Bridge Installation: see Figures 51, 52, 53

- Install the MicroSpan bridge assembly. The bridge assembly side plates (shaded grey in the illustration below) are positioned **outboard** of the frame assembly's side plates (see *Inset "A"*).



rev 05-02-08

Figure 51: Transfer Bridge installation - MicroSpan Transfer

STEP 10 — Install Transfer Bridge: MicroSpan Transfer (continued)

- Ensure that Transfer Bridge's support rods are correctly installed into Frame Assembly's seating pockets (Figure 52).

NOTICE

If the actual MicroSpan Transfer assembly does not match the illustrations shown in Figures 51, 52, and 53, the Transfer's side plates need to be adjusted so that the Transfer bridge is seated correctly.

NOTICE

There should be 1mm (0.04") clearance between the top land of a gear tooth and the bottom land of the tooth it meshes with on the mating gear (see Figure 53 detail).

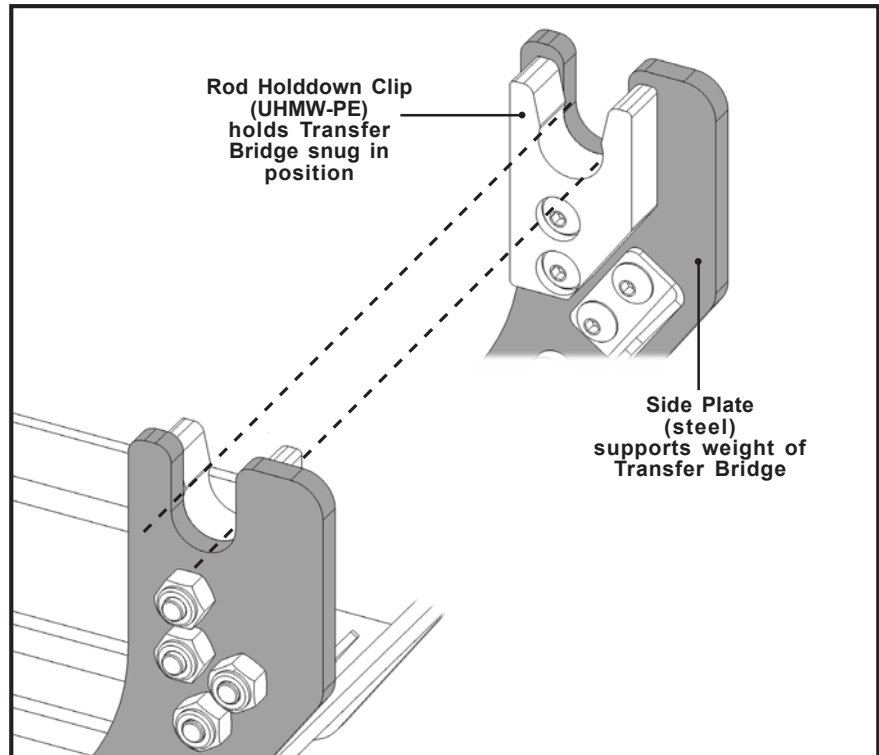

Figure 52: Transfer Bridge installation - seating pockets

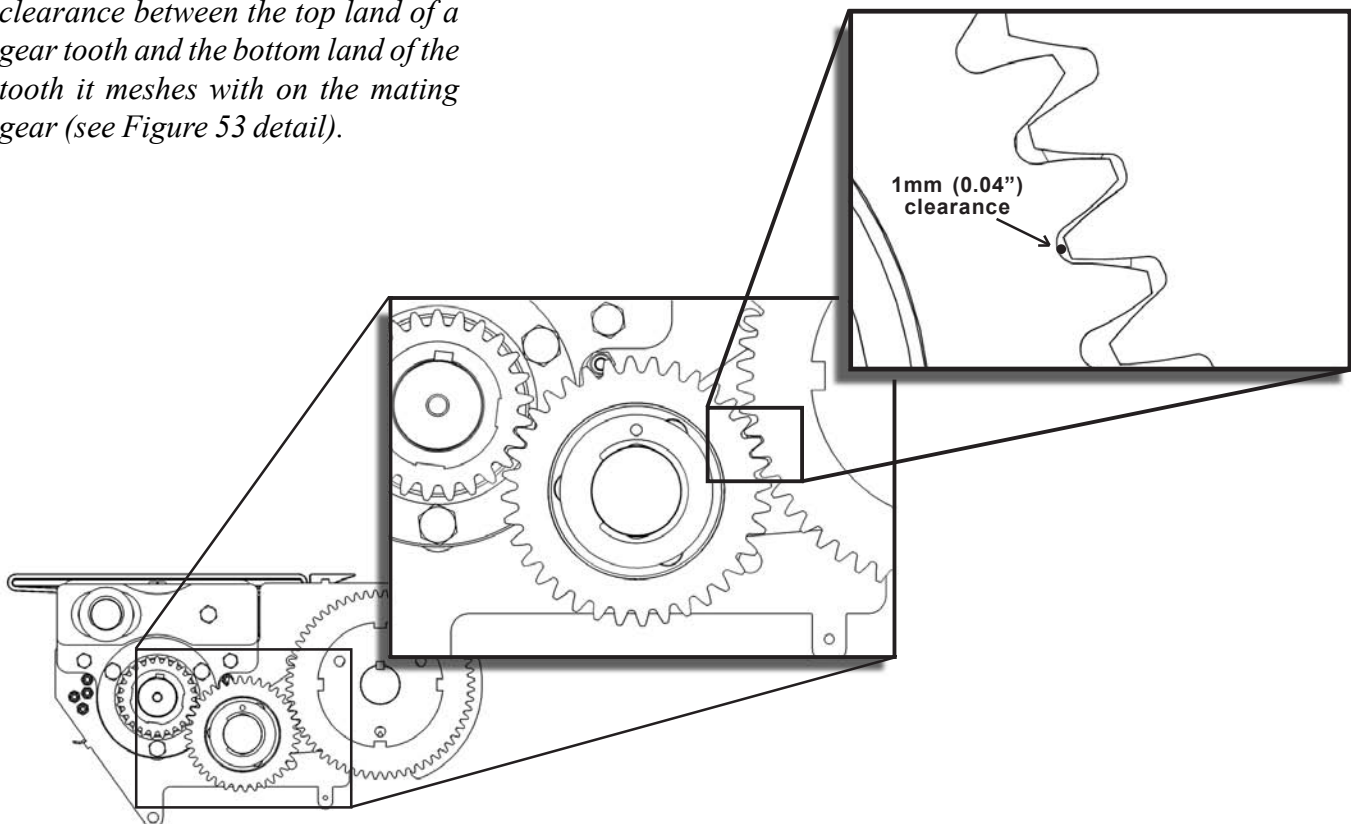

Figure 53: Detail of MicroSpan Transfer drive gear assembly



Side-Flexing Continuous Conveyors

PRE-OPERATION SAFETY CHECKLIST

Date: _____ Project No. _____

Time: _____ Conveyor No. _____

Evaluator: _____

Safety Evaluation Questions	YES	NO*	N/A
1. Are all safety devices installed and in good repair?			
2. Are all safety labels and placards installed where needed and in good repair? (order more if needed)			
3. Are control stations in proper working order, and in locations from which the conveyor is visible?			
4. Are Emergency Stops / stations in proper working order?			
5. Are warning signals or procedures, intended to inform personnel that the conveyor is about to start, in working order?			
6. Are conveyor chain links in good repair, with no unbroken links?			
7. Are all conveyor chain link Lock Tabs properly in place?			
8. Are the wearstrips (and associated components) in good repair?			
9. Is the conveyor chain properly lubricated?			
10. Is the drive motor amperage correct?			
11. Is the support structure in good repair (and anchored, if applicable)?			
12. Have all personnel working in the conveyor area been thoroughly trained on Emergency Stop locations and procedures?			
Additional Comments:			

* All items marked "No" require corrective action before operation.

this page intentionally left blank

Preventive Maintenance and Troubleshooting



Safety Guidelines and Information



WARNING

Failure to comply with the safety precautions and instructions provided in this manual could result in serious injury, death, or property damage.

- Read and follow all operating and product safety instructions.
- Read and observe all safety labels and warnings.
- Use proper lockout and tagout procedures following OSHA regulations prior to conveyor system maintenance.
- Only use parts supplied or authorized by Span Tech, LLC.
- In case of fire, use only water, foam, CO₂ or dry chemical extinguishers.
- Never climb or walk on the conveyor system unless necessary and authorized for maintenance purposes.
- Only authorized and trained personnel may perform maintenance on a conveyor's electrical control panel.
- Do not start conveyor until all personnel are clear.
- Keep clear of the conveyor area when equipment is energized; conveyor may start at any time.
- Do not place articles or extremities into conveyor chain or frame while in operation.
- Secure any loose clothing or hair; remove all jewelry, finger rings, pocket key rings, etc.
- Do not remove any guards or safety devices unless necessary and authorized for maintenance purposes.
- Restart the conveyor system at the device or location from which it has been stopped.
- Watch for low clearance points and the potential for falling overhead objects.
- Keep extremities clear from shear points and conveyor chain.
- Do not use Designer System[®] conveyors in prohibited environments. (Refer to *page 8* for information on prohibited environments. Refer to *page 46* for information on abrasive materials and contaminants.)

Routine Preventive Maintenance

Each conveyor system should be inspected according to the following procedures, and the results of each inspection recorded on the “Preventive Maintenance Items Checklist” provided on *page 53*. While the Designer System® conveyor is a complex engineered system, routine maintenance can be covered in only seven (7) basic steps. Each of these items should be checked to ensure a long, reliable conveyor life. If you have questions regarding any topic or problem not covered in this guide, feel free to contact Span Tech® for technical assistance.

Consistent preventive maintenance is a necessary safety practice. Regularly performed, preventive maintenance practices can help prevent damage to equipment and injury to personnel.

WARNING

Starting devices, prime movers, and powered accessories should be locked and tagged following OSHA regulations before maintenance or repair tasks are performed on any conveyor system. Only trained and qualified personnel who are aware of all safety hazards and how to avoid them should be allowed to perform maintenance procedures. Failure to comply could result in serious injury or death, or serious equipment damage.

1. Environmental Contamination Inspection – MONTHLY

- Inspect conveyor and its components for signs of contamination from environmental debris. If contamination is present, do not operate the conveyor until a thorough cleaning has been performed to remove the contamination.

Some components in a conveyor, especially the chain and wearstrips, can become contaminated by harsh or abrasive materials. Over time, small abrasive particles can become embedded in a conveyor’s plastic parts. This leads to excessive friction between the chain and wearstrip, and can ultimately reduce performance. A common source of abrasive contamination is construction occurring in the area of an exposed conveyor. Drilling, grinding, sawing, sanding, and other processes produce airborne abrasive dust which can build up on a conveyor.

Examples of abrasive materials include:

- Ceramic dust
- Metal chips
- Concrete dust
- Sugar
- Paper/wood dust
- Sand
- Medical tablet dust
- Broken glass particles
- Crumbs
- Corn meal

Sources of contamination include:

- Construction
- Product flaking
- Airborne delivery
- Product spillage
- Manufacturing processes
- Overhead equipment

Most abrasive contaminants can be removed by wiping down the top and bottom sides of the wearstrips, using a cloth moistened with rubbing alcohol.

2. Chain and Wearstrip Inspection – MONTHLY

The wearstrip is one of the most important features of a Span Tech conveyor system. The conveyor chain is designed with legs on the outer (side) links that hook around the lips of the conveyor side frame. Typically, a Spanlon wearstrip is fitted over the lips of the side frame. The conveyor chain contacts the wearstrip resulting in smooth chain travel, reduced load on the motor, and prevention of chain damage which could be caused by direct metal contact. A derailed chain is most often caused by wearstrip problems. Special attention must be given to the installation, maintenance, and repair of the wearstrips.

- Inspect the conveyor chain for broken links. Damage to chain can occur by dropping a heavy item on the chain links, or by a process jam. Promptly replace any broken links. The links immediately before and after the broken links should also be replaced due to possible material fatigue.
- Inspect the chain link Lock Tabs. It is very important to verify that all chain link Lock Tabs are properly in place. If not broken, snap any loose tabs back into place using a flat screwdriver. If broken, replace immediately.
- Inspect the leg and foot tab of the side links for wear. See illustrations *below*. If leg or foot tab measures less than dimensions shown in right-hand columns above, link is excessively worn and should be replaced.



Inspect Chain for broken links

Normal side link		Side link w/ worn leg	
7.80mm	MonoSpan	< 6.85mm	
8.40mm	MultiSpan	< 7.15mm	
8.40mm	MaxiSpan	< 7.15mm	

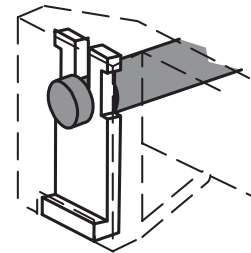

Inspect chain link Lock Tabs for proper fit

Normal side link		Side link w/ worn foot tab	
4.00mm	MonoSpan	< 2.00mm	
4.00mm	MultiSpan	< 2.00mm	
4.15mm	MaxiSpan	< 2.15mm	

- Inspect wearstrips to verify that all are in place and are properly installed. The wearstrip sections must not overlap. The ends of the wearstrip sections must be cut at the correct angle for the chain travel direction, and the gap width between sections must be sized according to temperature. NOTE: For bidirectional conveyors, the wearstrips should be cut “square” and positioned end to end (touching).
- Inspect wearstrips for signs of overheating.

3. Drive / Idler Wearstrip and Side Plate Inspection – MONTHLY

- Inspect the drive / idler wearstrips (often called “horseshoes”) for excessive wear or improper installation. Ensure that the drive / idler wearstrips are correctly cut, pressed completely onto the Side Plates, and correctly pinned. The wearstrips must not be disengaged from the ends of the Side Plates.
- Inspect Side Plates for damage or excessive wear.
- Inspect for loose or missing fasteners in the drive and idler units.

The drive / idler wearstrip is a key element in the design of the drive and idler units. This curved wearstrip guides the chain around the side plates, and carries the load as the chain travels around the sprockets.

4. Foreign Object Interference Inspection – MONTHLY

Interference from foreign objects is a primary cause of excessive wear on the chain surface. Interference can also result in broken chain links and rods, and damage to the drive and idler sprockets. If the drag becomes great enough, the motor current will increase and the Side Plates can fail. Interference can be prevented or corrected by removing all foreign objects from the vicinity of the conveyor, and by adjusting the position of any components or accessories which may come into contact with the chain.

- Inspect chain for any foreign objects that may be interfering with chain movement. Adjacent machines or conveyors must not be in contact with the moving chain.
- Ensure that no interference is occurring at the loading or unloading points of the conveyor system.
- Inspect transfer devices to ensure that components (transfer plates, transfer fingers, etc.) are not contacting the moving conveyor chain.
- Ensure that all guide rails, guide rail brackets, raised side walls, chain support rails, drip tray brackets, and other accessories and components are clear of the conveyor chain.
- Inspect entire conveyor for bolts, fasteners, tools, and other debris.

5. Chain Slack and Sprocket Engagement Inspection – MONTHLY

Over time, normal wear and elongation of chain links can contribute to an increase in chain slack. An improper amount of slack in the chain can lead to excessive motor current. It can also cause the chain to “jump teeth” on the sprockets. Chain slack can be adjusted by removing or adding rows of chain links.

- Check the overall amount of slack in the chain (3 to 4 links compression recommended).
- Check for excessive chain slack immediately after the drive sprockets.
- Ensure that the sprocket teeth are not engaging or contacting any High Friction chain links.

6. Lubrication and Lubricator Inspection – EVERY 15 DAYS

Conveyor Systems WITH Lubricators:

- Check the adjustment of wearstrip lubricators.
- Check the fill level of the lubricator reservoir; add lubricant if needed.

Conveyor Systems WITHOUT Lubricators:

- Manually lubricate wearstrips, as follows:
 - Where your operation and product allow, use **SpanLube** silicone oil (Span Tech part number *DS0000*). **SpanLube** greatly reduces the chain tension and lowers friction by lubricating the area where the wearstrips and side links meet.
 - With the conveyor STOPPED, lightly drip oil in the area where the conveyor chain and wearstrip meet on the bottom side of the conveyor. The chain will then distribute sufficient lubrication to the rest of the system.
 - Do not use silicone oil if your product will be contaminated by the oil. Once silicone oil is applied, it is very difficult to remove.

Powered Roller Transfers:

- Inspect the oil level sight glass on the Transfer Chassis oil reservoir. Refill with lubricant as needed.

Gearmotor Lubrication:

- Inspect the lubricant levels in the motor gearboxes, following the guidelines recommended by the manufacturer. Refer to manufacturer's documentation.



Lubricate the conveyor wearstrip with silicone oil



Bottle of SpanLube

7. Measurement of Motor Current – MONTHLY

- Measure the current requirements for all 3-phase AC drive motors. Compare the measured value to the value shown on the motor's specification plate. Keep a log of the measured values.

NOTICE

Excessive amperage indicates a problem in the system that should be immediately diagnosed and corrected by qualified personnel. Failure to comply could result in damage to equipment and system downtime.

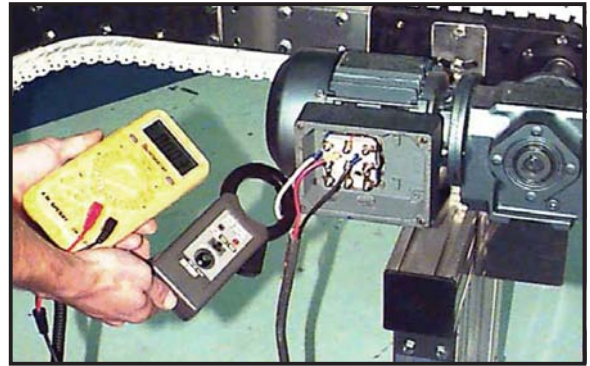

Checking drive motor amperage

Preventive Maintenance Items Checklist

- Environmental Contamination Inspection (PAGE 46).
- Chain and Wearstrip Inspection (PAGE 47).
- Drive / Idler Wearstrip (“Horseshoe”) and Side Plate Inspection (PAGE 48).
- Foreign Object Interference Inspection (PAGE 49).
- Chain Slack and Sprocket Engagement Inspection (PAGE 50).
- Lubrication and Lubricator Inspection (PAGE 51).
- Measurement of Motor Current (PAGE 52).

Maintenance Procedures

The following section (pages 54 through 90) provides complete information for 24 specific maintenance tasks and topics. Refer to the Table of Contents (page 4) for a listing of all 24 procedures.

WARNING

Starting devices, prime movers, and powered accessories should be locked and tagged following OSHA regulations before maintenance or repair tasks are performed on any conveyor system. Only trained and qualified personnel who are aware of all safety hazards and how to avoid them should be allowed to perform maintenance procedures. Failure to comply could result in serious injury or death, or serious equipment damage.

Part A: Preventing Environmental Contamination

Some components in a conveyor, mainly the chain and wearstrip, can become contaminated if subjected to harsh abrasive materials. Over time, small abrasive particles can become embedded in a conveyor's chain and/or wearstrip. This leads to excessive friction between the chain and wearstrip, and can ultimately result in performance problems.

Construction in the area of an exposed conveyor is a common source of abrasive contamination. Drilling, grinding, sawing, sanding, etc. produces airborne abrasive dust which can build up on nearby conveyors.

Some examples of abrasive materials are:

- Ceramic dust
- Paper/wood dust
- Crumbs
- Metal chips
- Sand
- Broken glass particles
- Concrete dust
- Medical tablet dust
- Corn meal
- Sugar

If construction is to be carried out anywhere near a conveyor, first remove the conveyor chain and store it in an airtight plastic bag(s). When the construction has been completed, clean all areas of the conveyor frame. If possible, wash the conveyor frame down with water. Then, reinstall the chain.

If the dust produced by construction is not cleaned off the conveyor, it can become embedded in the chain and/or wearstrip, leading to permanent damage.

Contamination can also result from an unforeseen environmental condition such as build up of residue from the customer's product, etc.

Exposing a conveyor to certain harsh chemicals may also contaminate conveyor components. Refer to the *Chemical Compatibility Chart* (pages 90-97) for data concerning the effect of various chemicals on plastic conveyor components. Also refer to *Part W* on page 87 for additional information.

NOTICE

Do not run a conveyor that has been exposed to contaminating materials. The conveyor should be thoroughly cleaned to remove the contamination. Failure to comply could result in damage to equipment. (See Part B, page 55, for recommended cleaning procedures.)

Part B: Cleaning

Cleaning Conveyors

The components in Designer System® products are made from a variety of metal, plastic, and composite materials. Care should be taken to remove soils with the least corrosive detergent possible. It is very important to keep your Span Tech conveyor system clean to ensure proper operation.

NOTICE

Using a higher than recommended concentration of detergent is not beneficial and can harm the conveyor system.

Recommended General Cleaning Procedure for Conveyors:

1. Water is the most important cleaning agent. It should be used to remove 85% - 90% of all foreign material on a conveyor system. For the best results in dissolving soils, keep the water temperature between 90°F - 135°F (32°C - 57°C).
2. When necessary, the conveyor system should be foamed, scrubbed, or soaked with an inhibited alkaline detergent at the recommended concentration. Facilities that must meet USDA requirements will clean with this detergent on a daily basis. All other facilities should clean with detergent quarterly.
3. It may be necessary to open the chain and remove soils from the conveyor's wearstrips, sprockets, center support rails, and return chain support rails by hand washing.
4. Remove the chain from the conveyor to use high pressure spray.
5. Never allow detergents to dry on the conveyor.
6. Soil and detergent should be completely rinsed from the conveyor with plain water. For rinsing, the water temperature should be kept between 70°F - 90°F (21°C - 32°C).
7. Facilities meeting USDA requirements should apply a recommended concentration of mild citric acid once a month to remove any dried soap or mineral deposits from the system. Rinse the mild citric acid solution away from the system with plain water.

NOTICE

Reference the Chemical Compatibility Chart (pages 90-97) to determine a component's level of resistance to specific chemicals.

Components made of acetal and nylon materials are not resistant to organic or mineral acids such as phosphoric acid, sulfuric acid, nitric acid, hydrochloric acid, etc.

Components made of acetal material are not resistant to hypochlorite solutions.

Contact with non-resistant materials by acids or hypochlorite solutions can result in damage to components and system downtime.

Part B: Cleaning

Cleaning Powered Transfer Units

Cleaning the Chassis:

1. Remove the transfer bridge from the chassis.
2. Lightly hose the contaminated area of the chassis. Hot water may be used.

NOTICE

Never use high-pressure spray to clean a transfer unit chassis. Bearing failure will occur.

3. Use a soft - bristled brush to apply cleaning solution. A mild dish detergent is recommended.
4. Rinse off the cleaning solution before it dries.
5. Operate the transfer unit until it is completely dry.

Cleaning the Transfer Bridge:

1. Remove the transfer bridge from the chassis.
2. Lightly hose the contaminated area of the bridge. Hot water may be used.

NOTICE

Never use high-pressure spray to clean a transfer unit bridge. Bearing failure will occur.

3. Use a soft-bristled brush to apply cleaning solution. A mild dish detergent is recommended.
4. Rinse off the cleaning solution before it dries.
5. Reinstall the transfer bridge, and operate the transfer unit until it is completely dry.

Part C: Wearstrip Installation

The wearstrip is one of the most important features of Span Tech's Designer System® conveyors. The conveyor chain is designed with legs on the outer links that hook around the lips of the conveyor side frame. The lips of the side frame have a Spanlon wearstrip fitted over them. The conveyor chain contacts this wearstrip, resulting in smooth chain travel, reduced load on the motor, and the prevention of damage caused by the chain directly contacting the metal side frame. Special care must be taken when installing the wearstrips.

NOTICE

Failure to read and follow these instructions could result in damage to the conveyor system.

Connecting Pre-Cut Wearstrips

If the conveyor system being installed has been field broken for shipping purposes, the wearstrips at the break locations have already been properly trimmed according to the direction of chain flow and the environment in which the system will operate. In this case, simply push the wearstrips into place on the frame lips and proceed to the directions for pinning wearstrip.

Before Cutting Wearstrips (if necessary)

Four factors must be considered before making cuts: **temperature, cut angle, cut direction, and cut location.**

TEMPERATURE: The temperature at which the wearstrip is installed in a conveyor, as well as the temperature at which the conveyor will normally be operating, both need to be considered before the wearstrips are cut and trimmed. Cooler operating temperatures cause the wearstrips to contract or become shorter. Warmer operating temperatures cause the wearstrips to expand or become longer.

At Span Tech, conveyors are pre-assembled at an average room temperature of about 70° F (21° C). If the conveyor is installed in a room with an average temperature of 20° F (-7° C), the wearstrip will naturally contract. When the wearstrip contracts, the gap between adjacent pieces gets wider. If the gap gets too wide, the conveyor's chain could derail from the system. On the other hand, if the conveyor is installed in a room with an average temperature of 100° F (38° C), the wearstrips will expand, causing the gap between adjacent pieces to get smaller. One wearstrip could even start to overlap onto the next, possibly resulting in damage to the conveyor.

The gap between adjacent wearstrips should be maintained at or very near 1/4" (6.4mm). The Wearstrip Gap Chart (*below*) indicates the gap that should be left between adjacent wearstrips at various installation temperatures, as compared to various temperatures at which the conveyor will operate. *Example:* If the wearstrips are installed in a conveyor at a room temperature of 60° F (15.5° C), but the conveyor will normally be operating in a 100° F (38° C) environment, you should leave a 3/8" (9.5mm) gap between wearstrips as they are installed.

WEARSTRIP GAP CHART

		NORMAL OPERATING TEMPERATURE					
		0° – 20°F -17.8° – -6.7°C	21° – 40°F -6.1° – 4.4°C	41° – 60°F 5.0° – 15.5°C	61° – 80°F 16.1° – 26.7°C	81° – 100°F 27.2° – 37.8°C	101° – 120°F 38.3° – 48.9°C
INSTALLATION TEMPERATURE	0° – 20°F -17.8° – -6.7°C	1/4"	5/16"	7/16"	1/2"	9/16"	5/8"
	21° – 40°F -6.1° – 4.4°C	6.4mm	7.9mm	11.1mm	12.7mm	14.3mm	15.9mm
	41° – 60°F 5.0° – 15.5°C	3/16"	1/4"	5/16"	3/8"	1/2"	9/16"
	61° – 80°F 16.1° – 26.7°C	4.8mm	6.4mm	7.9mm	9.5mm	12.7mm	14.3mm
	81° – 100°F 27.2° – 37.8°C	1/8"	3/16"	1/4"	5/16"	3/8"	1/2"
	101° – 120°F 38.3° – 48.9°C	3.2mm	4.8mm	6.4mm	7.9mm	9.5mm	12.7mm
	0° – 20°F -17.8° – -6.7°C	1/16"	1/8"	3/16"	1/4"	5/16"	3/8"
	21° – 40°F -6.1° – 4.4°C	1.6mm	3.2mm	4.8mm	6.4mm	7.9mm	9.5mm
	41° – 60°F 5.0° – 15.5°C	0"	1/16"	1/8"	3/16"	1/4"	5/16"
	61° – 80°F 16.1° – 26.7°C	0mm	1.6mm	3.2mm	4.8mm	6.4mm	7.9mm
	81° – 100°F 27.2° – 37.8°C	0"	0"	1/16"	1/8"	3/16"	1/4"
	101° – 120°F 38.3° – 48.9°C	0mm	0mm	1.6mm	3.2mm	4.8mm	6.4mm

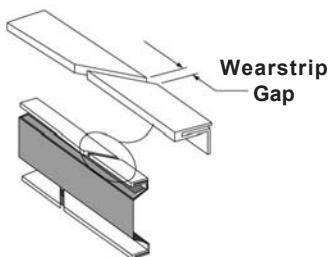

Part C: Wearstrip Installation

Cut Angle

The ends of adjoining wearstrip sections should be trimmed at 60° angles, as shown in *Figure 10*. This angle, in conjunction with the direction in which the angles are cut (discussed below), allows the chain to travel smoothly over the wearstrip joint.

Cut Direction

The direction in which the conveyor chain will travel dictates the direction at which the wearstrip angles will be cut. *Figure*

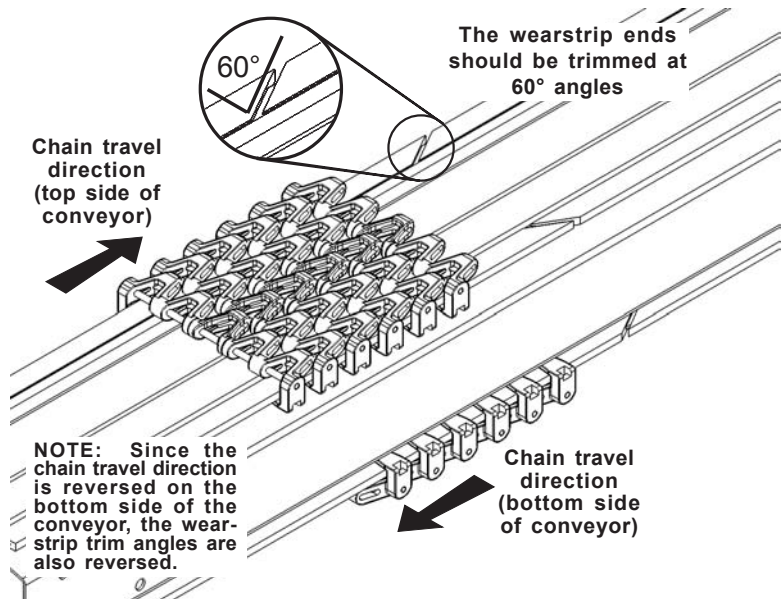

Figure 53 Overview of Wearstrip assembly

Replacing Wearstrip in Horizontal Bends

Each wearstrip in a horizontal bend should run continuously, without a break. If the bend is too large for this, use two wearstrip sections, joining them in the center of the bend. The ends of the wearstrips should run out at least 10" (254mm) onto the straight bed sections attached to the bend. As shown in *Figure*

Part C: Wearstrip Installation

Installing New Wearstrip in Horizontal Bends

1. Using the Rivet Insertion Tool provided, install rivets in the straight bed section coming out of the bend (inside, outside, top, and bottom). Refer to *Figure 5*

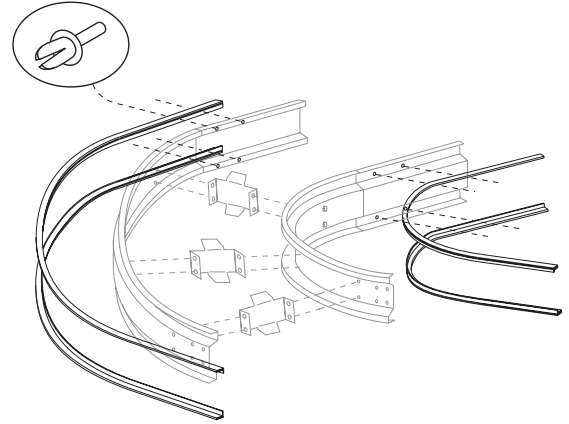

Part C: Wearstrip Installation

- 4. Push the wearstrips into the outside of the bend until the wearstrip is completely bottomed out against the side frame. Refer to *Figure*

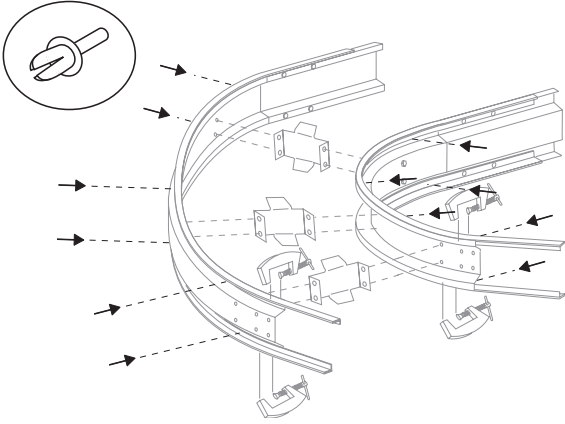
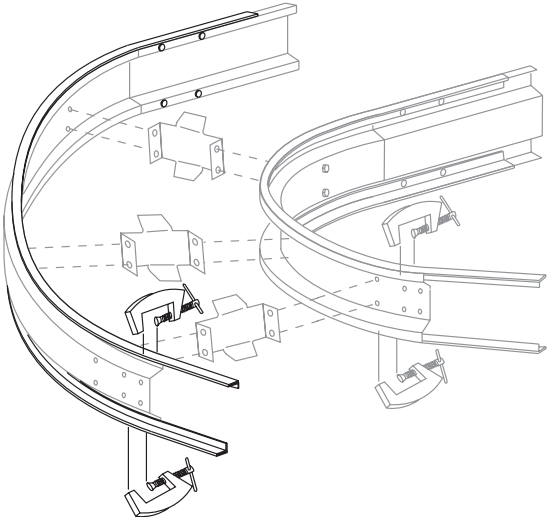

7. Trim the ends of the horizontal bend wearstrips to form the proper gap and angle in relation to the ends of the straight section wearstrips. Drill all the holes for the wearstrip rivets in the wearstrips. Then install the wearstrip rivets to finish the job. Refer to *Figure*

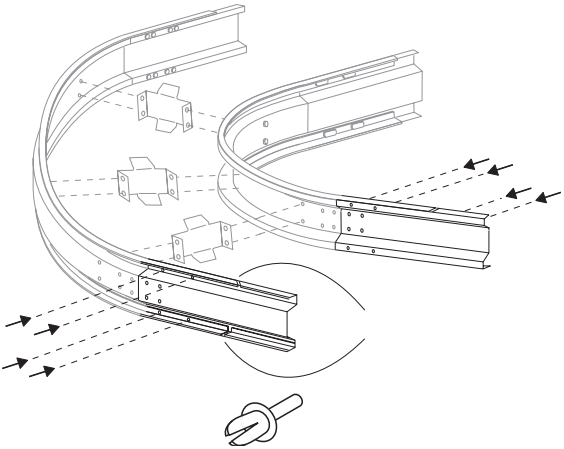

Part D: Overheated Wearstrips

Wearstrips may overheat for various reasons, including: the conveyor is **overloaded**; the lip-to-lip **width of the conveyor is over tolerance**, especially in bends; the conveyor has become **contaminated**; or the wearstrips have **expanded and overlapped**.

Overheating Wearstrips in Horizontal Bends

The wearstrips in a bend will usually begin to overheat in the area we call the “hot spot.” As the conveyor chain travels around a curve, friction can cause heat to build up around the curve’s outside radius. The hot spot is the area where the most friction is produced.

“Pulled” Conveyors

The hot spot in the curve of a “pulled” conveyor is located on the top outside of the curve, in the spot just before the chain exits the curve (*Figure*



Part E: Drives and Idlers

Assembly of DRIVE / IDLER UNITS with STAINLESS STEEL "HORSESHOES" (standard as of October, 2004):

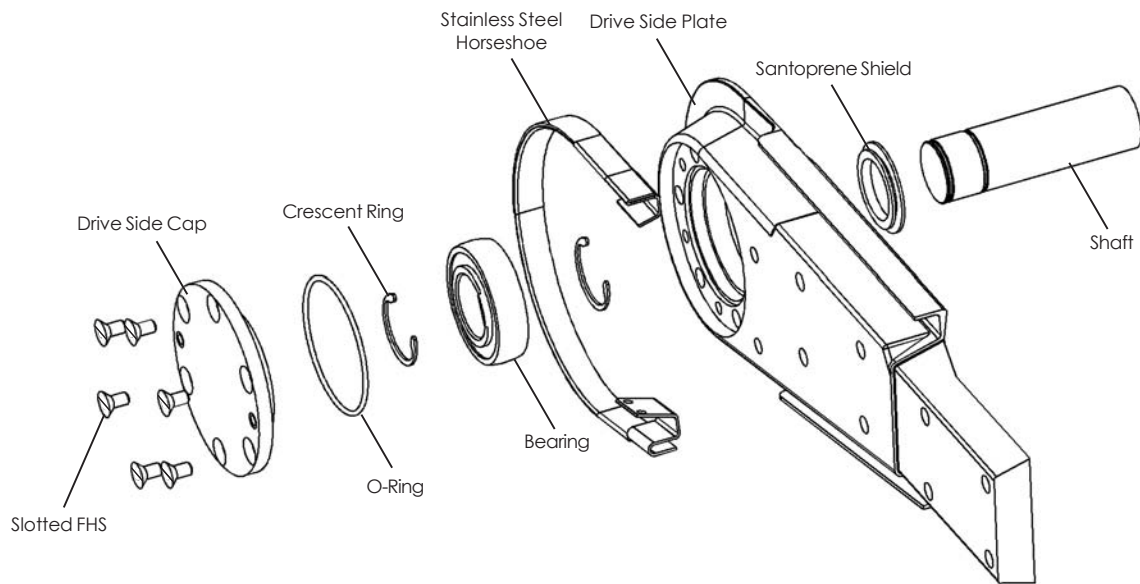

Part E: Drives and Idlers

Installing New (Stainless Steel) Drive / Idler Wearstrips “Horseshoes”

1. While holding the Drive Side Plate with the inboard side toward you (*Figure 67*), begin at right and work counterclockwise around the curve as you fit the horseshoe to the Plate (if you are left-handed, you may want to reverse this direction). Ensure that the four tabs are aligned with the recessed notch at the end of the Drive Side Plate (*Figure 68*).

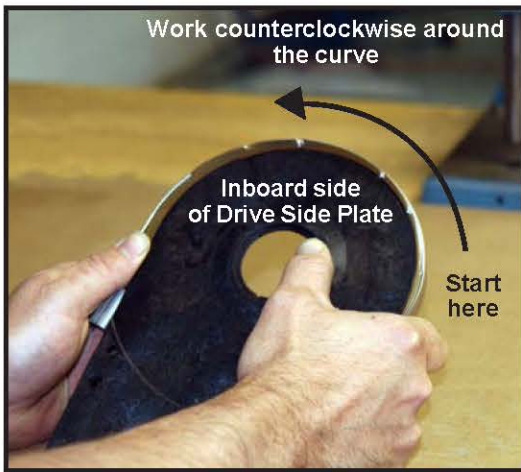

Figure 67

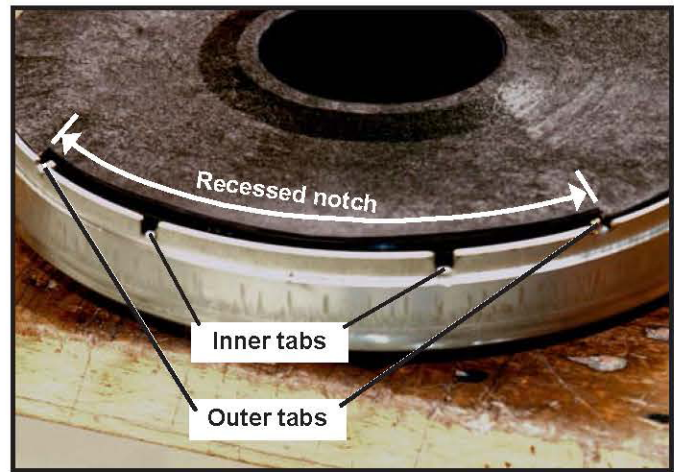

Figure 68

2. Once the horseshoe is fitted onto the Drive Side Plate, attach a clamp to hold it in position (*Figure 69*).
3. Using a 7/64” (3mm) drill bit, drill two pilot holes into the Drive Side Plate, through the existing holes in the horseshoe’s mounting ear (*Figure 70*).

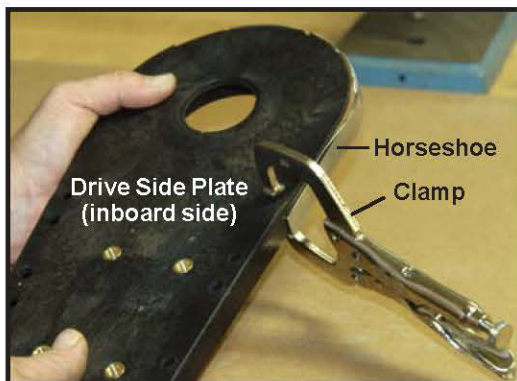

Figure 69

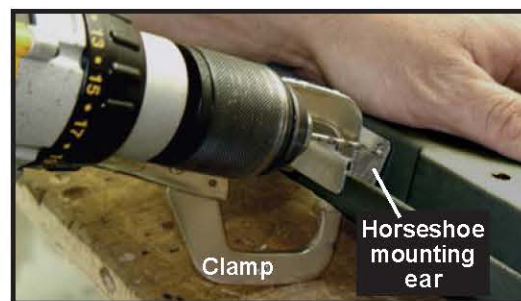

Figure 70

4. Install two Phillips pan head screws into the pilot holes, and tighten. Remove the clamp.

Part E: Drives and Idlers

5. Manually fit the horseshoe around the curve of the Drive Side Plate (*Figure*

Part F: Lubricator Adjustment

Adding the Lubricant

Fill the lubricator at the top of the reservoir as shown in *Figure*

Part G: Powered Transfer Lubrication

Checking the Oil Level

Check the oil level in each powered transfer unit periodically. Refer to *Figure*

Part H: Motor Amperage & Gearbox Temperature

3-Phase AC Motor Amperage



Only trained and authorized personnel should perform this procedure. Failure to comply with these instructions and safety precautions could result in serious injury or death.

Use a clamp-on type multimeter to measure the actual running amperage of a 3-phase AC motor.

Hold the clamp around each of the motor's three power leads (excluding the ground lead) individually as shown in *Figure*

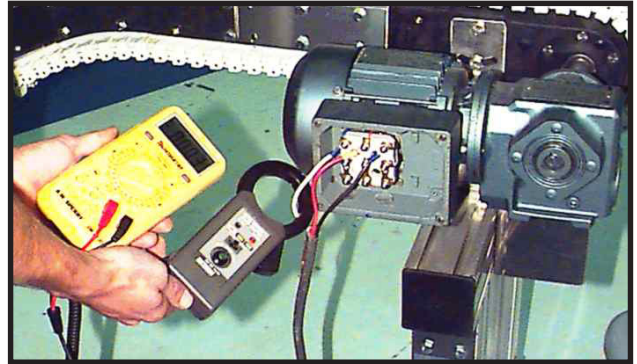

Figure 78

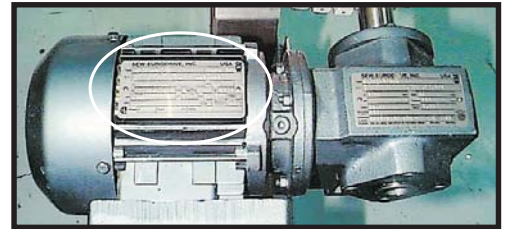

Figure 79



SEW - EURODRIVE, INC.		U.S.A. SE	
Type	<input type="text"/>		
S.O.	<input type="text"/>		
V	<input type="text"/>	Hz	<input type="text"/>
A	<input type="text"/>	Code	<input type="text"/>
Hp	<input type="text"/>	S. F.	<input type="text"/>
rpm	<input type="text"/>	Inrs Class	<input type="text"/>
Brake	<input type="text"/>	Torque	<input type="text"/>
		lb - ft	Control
			<input type="text"/>

Figure 80

Part H: Motor Amperage & Gearbox Temperature

Gearbox Temperature

Measure the actual running temperature of the gearbox. If using an infrared pyrometer, aim at the surface of the gearbox while holding the thermometer about 1 ft. (30cm) away as shown in *Figure*

Part I: Sprocket Orientation

MonoSpan and MultiSpan

MonoSpan and MultiSpan sprockets (*Figure*

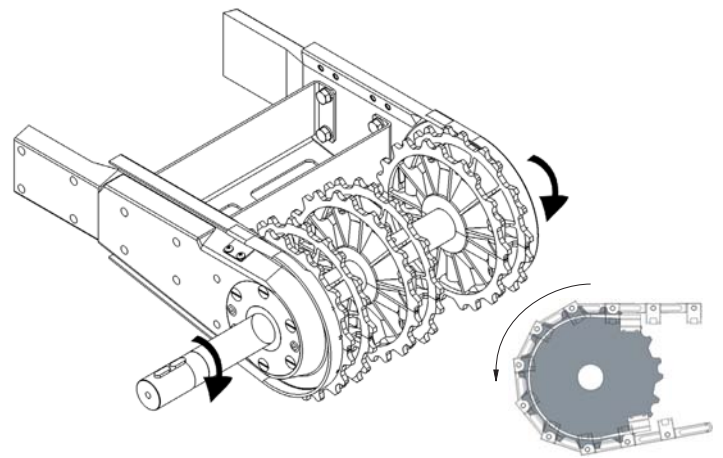

Part J: Sprocket Alignment

Ensure that the teeth of all the sprockets that are common to one shaft are in alignment across the shaft.

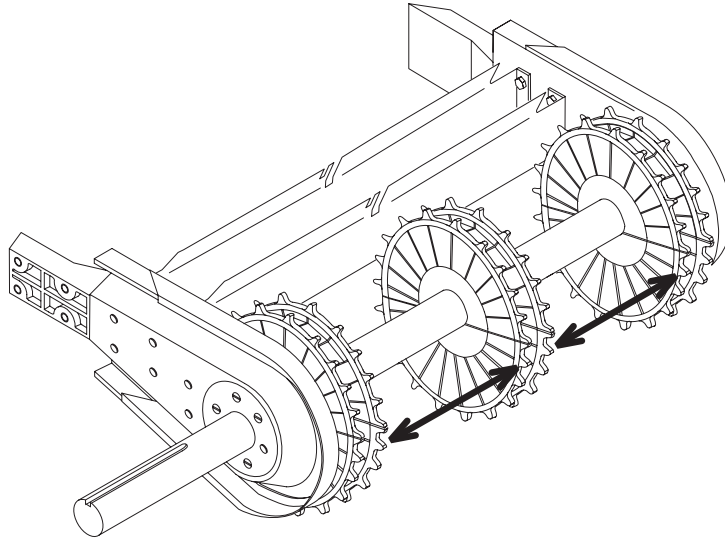

Figure 88: Correct MultiSpan Sprocket Alignment Across Drive / Idler Shafts

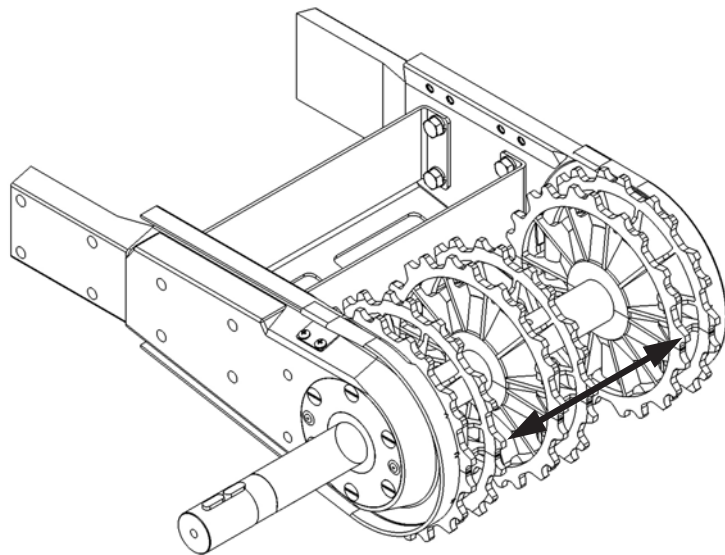

Figure 89: Correct MaxiSpan Sprocket Alignment Across Drive / Idler Shafts

Part K: Sprocket Installation

Sprocket Installation Notes

Be sure the sprocket halves are seated down onto the reinforcement plate and sprocket key. They should fit snug on the shaft when the bolts are tightened.

Be sure the shear pin is seated in the provided slot in the reinforcement plate. The sprocket should not rotate or move from side-to-side on the shaft.

Once the sprockets are installed, be sure they are perpendicular to the shaft.

Be sure the outer sprockets do not rub against the drive / idler side plates.

Replace any sprocket that is noticeably warped. This can easily be seen by rotating the shaft several times while looking straight down into the drive / idler.

Be sure the half-tooth on the top sprocket half matches up with the half-tooth on the bottom sprocket half (*Figure*

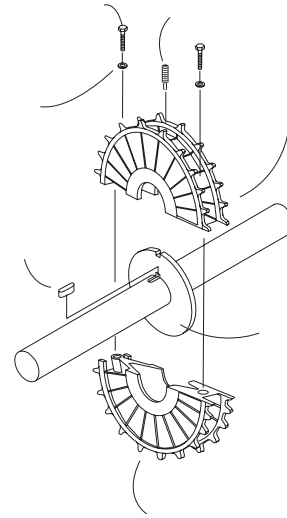

Part L: Chain-to-Sprocket Engagement and Chain Installation Direction

The chain links should always engage the sprocket(s) teeth as shown in *Figures*

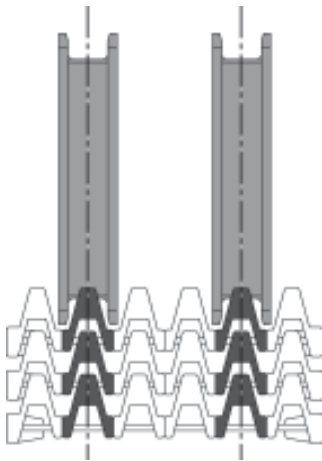

Part M: Sprockets Rubbing Side Plates

Sprockets should **not** rub against the drive / idler side plates (*Figure*

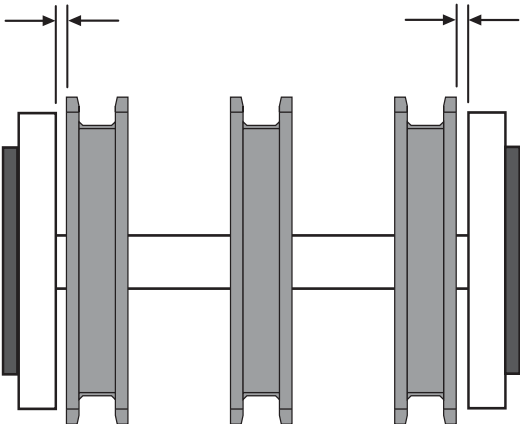

Part N: Bound or Locked Idler Shaft

A bound or locked idler shaft in a conveyor increases the torque required to keep it in operation. Ultimately, this results in motor overload and failure.

Possible Causes of Bound or Locked Idler Shafts

- The Idler's outer sprockets are rubbing against the side plates.
- Bearing failure.

Correcting Bound or Locked Idler Shafts

- Loosen the bolts in the sprocket that is rubbing against the side plate. Place a shim plate 0.075" (2mm) thick between the side plate and the sprocket, as shown in *Figure*

Part O: Broken or Bent Chain Rods

Bent chain rods, like those illustrated in *Figure 99*, are often the result of heavy loads concentrated in the center of the chain. This can distort the chain and change how the side links contact the wearstrip. Badly bent chain rods will cause accelerated wear to both the wearstrip and the chain's side links. Bent chain rods can also increase the amount of torque required to run the conveyor, which in turn can stress the conveyor's motor.

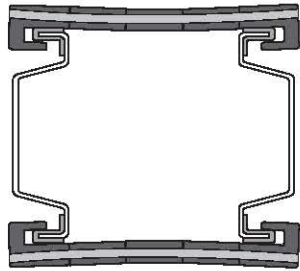

Figure 99

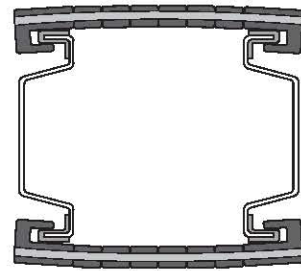

Figure 100

Though not as common, certain applications can cause the chain rods in a conveyor to bend upward like those illustrated in *Figure 100*. This can happen in roller or tube top type chains where there is an open space between consecutive chain rods. When the product is placed onto the conveyor in a way that its edge can catch under the chain's rollers or tubes, as shown in *Figure 101*, the chain can be lifted upward. This can eventually lead to bent or broken chain rods.

Figure 102 is a photographed example of bent chain rods.

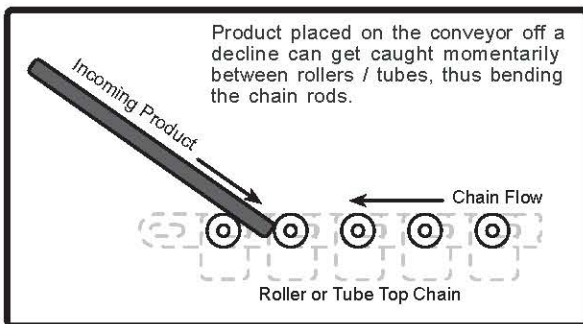

Figure 101

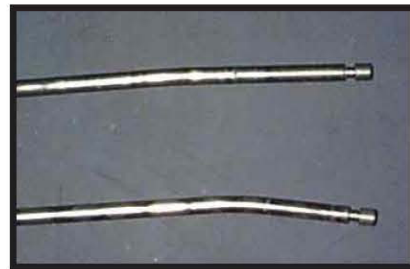
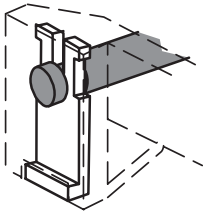

Figure 102 Bent Chain Rods

Part P: Chain Assembly

Figures



Part Q: Center Support Rail

The center support rails provide support for the top chain in the product zone, thus preventing the chain from bowing due to the product load.

As a rule, all widths of MaxiSpan conveyors require center support rails.

MultiSpan conveyors that are 13.21” (335.6mm) or wider require center support rails.

MonoSpan conveyors do not require center support rails.

General Notes About Center Support Rail

- Center support rails should “snake” back and forth throughout the length of the conveyor, as shown in *Figures 108 & 109*, to avoid wear in one particular spot under the chain.

NOTICE

Figures 108 & 109 are shown as typical examples; actual layout and appearance of center support rails for specific applications may vary.

- As a general rule of thumb, MaxiSpan conveyors will have one center support rail weaving under each of the chain’s center links.
- MultiSpan conveyors will require a varying number of center support rails depending on the specific chain pattern and width. In this case, refer to job prints to determine the number and location of the center support rails.

NOTICE

A center support rail should never be positioned under High Friction or roller type chain links. If the chain includes High Friction or roller links, the rail should run under the acetal center links only. This will reduce the chance of the rail coming into contact with High Friction or roller links — a situation that can cause excessive drag and premature failure of the conveyor.

At field break locations, the trailing end of a center support rail should extend beyond the leading end, as shown in *Figure 110* so that support is not interrupted.

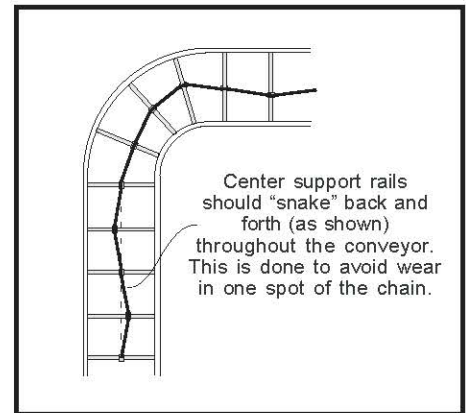

Figure 108

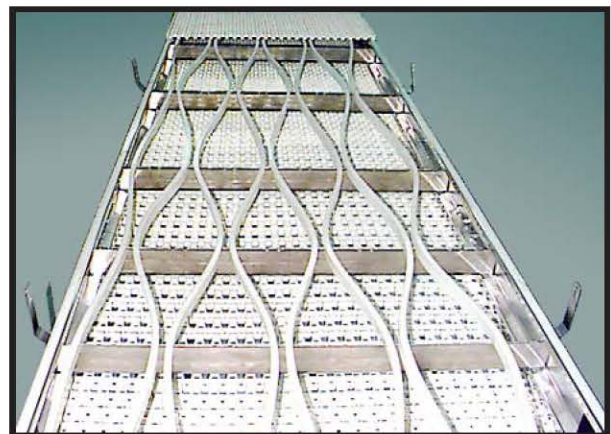

Figure 109

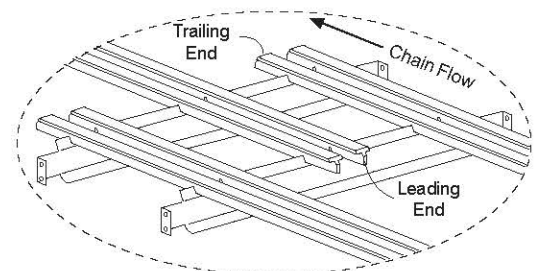

Figure 110: Center Support Rail at Field Break location

Part Q: Center Support Rail

Center Support Rail Installation

1. Hold the trailing end of the center support rail in position and make a mark at the location it should be cut.
2. Use pruning shears to cut the center support rail at the mark.
3. Using the pruning shears, chamfer the end of the rail.
4. At field-break locations, insert the T-rail into the crossbar slot closest to the edge of the conveyor.
5. Using a rubber mallet, tap the T-rail to fully seat it in the crossbar slot. The self-locking tab will lock the T-rail in position (*Figure 112*).
6. Inspect entire Center Support Rail to ensure that it is properly installed and secure at every crossbar.

NOTICE

If the center support rail is not completely seated in the crossbar slot, the rail will push up against the chain causing various problems such as additional chain pull, wear on the chain links, and increased wear of the wearstrips.

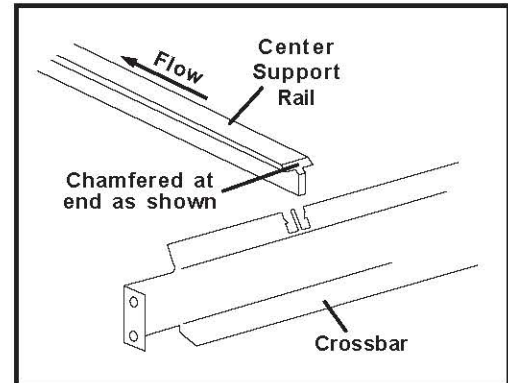

Figure 111

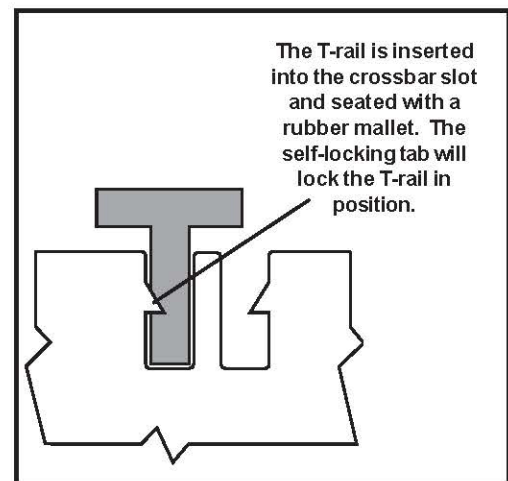
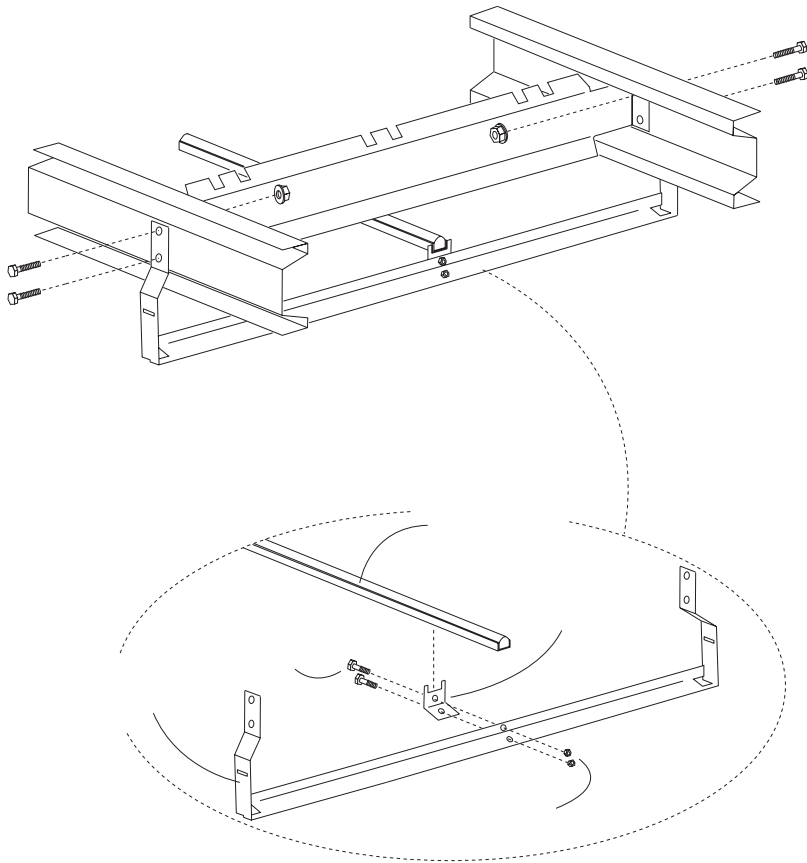

Figure 112

Part R: Return Chain Support Rail

Return chain support rail (Figure



Part S: Direction of Bed Sections

When installing a conveyor bed section, the upper lips of the crossbars should bend in the direction of chain flow as illustrated in *Figure 114*.

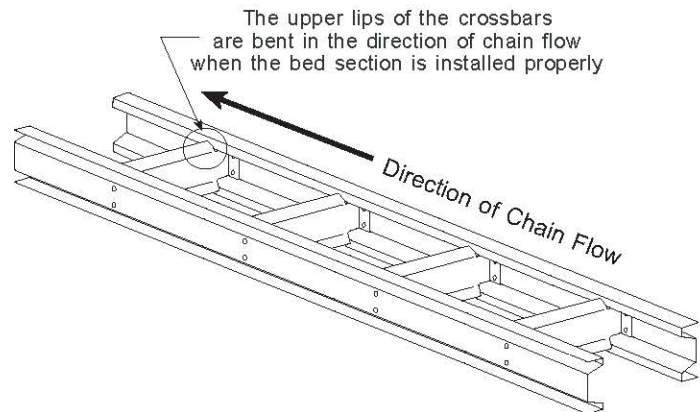

Figure 114: Correct Bed Section Installation Direction

If the upper lips of the crossbars in a bed section are bent in the opposite direction as the chain flow, the bed section is installed backward as illustrated in *Figure 115*. The only exception to this is in a conveyor that will run in both directions.

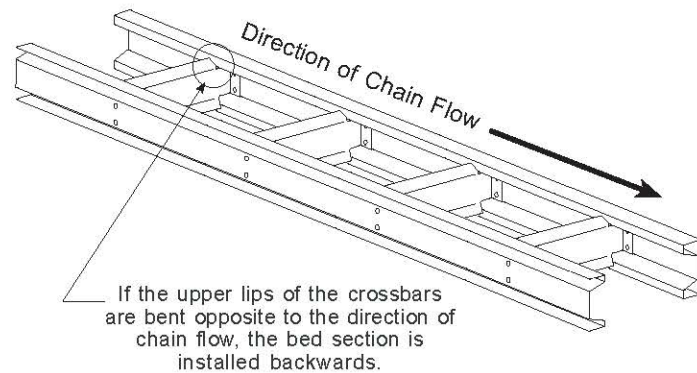
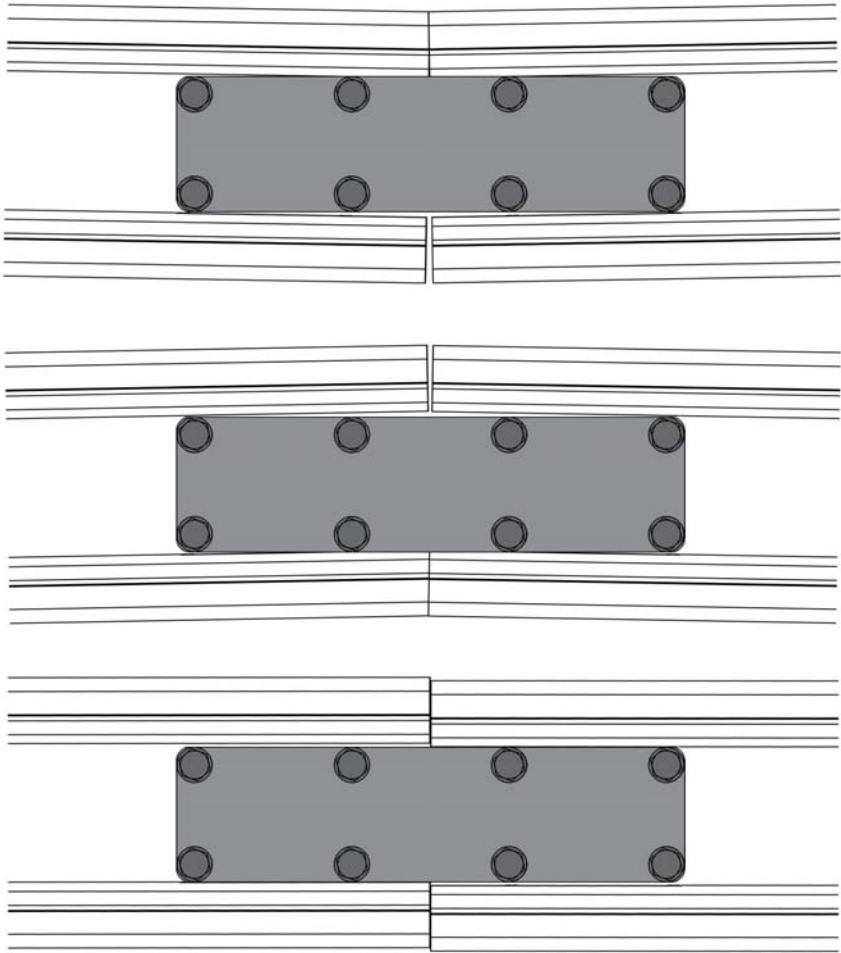

Figure 115 Incorrect Bed Section Installation Direction

Part T: Side Frame Alignment

Inspect the areas along a conveyor where bed sections join. The ends of the side frames should be aligned as illustrated in *Figure*



Part U: Horizontal & Vertical Bend to Straight Bed Section Alignment

Figure

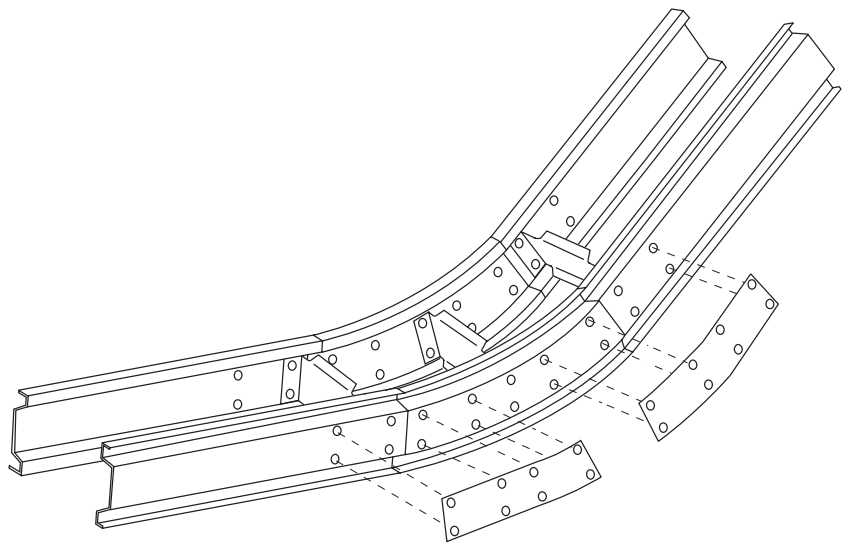
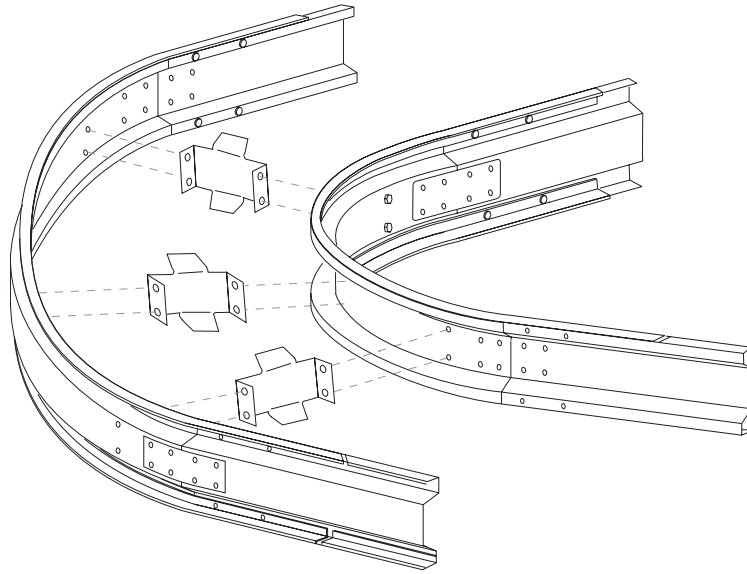

Part U: Horizontal & Vertical Bend to Straight Bed Section Alignment

Additional Inspection Tips:

- Be sure all connecting strap bolts are installed and tightened.
- Be sure the correct lip-to-lip width across the conveyor is maintained throughout the connection areas.
- Be sure the transition of the wearstrip across the side frame joints is smooth.
- Be sure the plastic vertical bend side frames are cut at the correct angle.
- Be sure the proper connecting straps are used.
- Be sure to install the correct number of crossbars in the vertical bend area, and be sure they are installed in the proper locations. Refer to *Figure*

Part V: Crossbars

Inspect the conveyor's crossbars. Replace any bent, damaged, or missing crossbars.

Refer to the job layout print that shows your conveyor(s) in a plan view to determine the correct quantity and placement of the crossbars. *Figure*

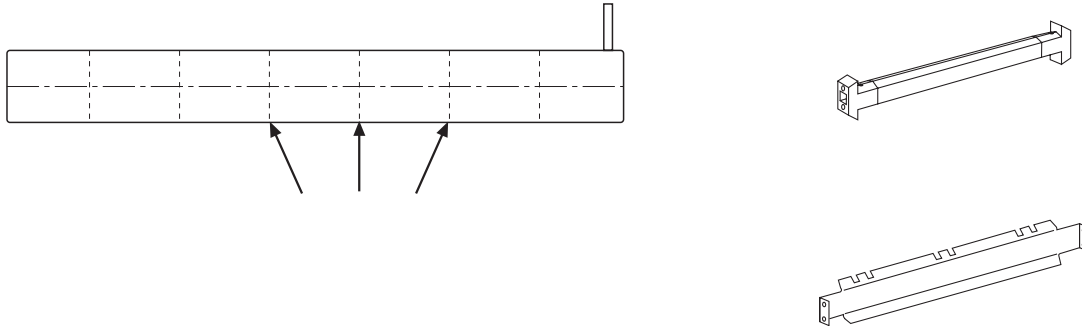

Part W: Chemical Contamination

Certain harsh chemicals can rapidly deteriorate plastic components and lead to premature failure. Different chemicals change the properties of the plastic components in different ways. For instance, the appearance of a chain that has been exposed to a certain chemical may not change, but the chain may have become brittle causing the links to break easily. Exposure to another chemical may change the appearance of the chain links.

A conveyor system can often be exposed to harsh chemicals during a cleaning process. Contact a Span Tech customer service representative to obtain Span Tech's recommended cleaning procedures.

Plastic components can be molded from polypropylene material which can withstand exposure to a wider range of chemicals than some of the standard materials used in normal environment applications. Polypropylene components are often used when a customer's product contains harsh chemicals.

To determine the resistance of various plastics used in Span Tech conveyor systems to specific chemicals, refer to the *Chemical Compatibility Chart* (pages 90 through 97).

As an example of chemical contamination, *Figures*

Part X: Chain Pitch & Elongation

Stretched Chain Links

The links in a chain can stretch after a prolonged period of conveyor operation. This stretch is minimal and is usually not significant in shorter conveyors.

In longer conveyors, however, this stretching can produce a functionally significant increase in the amount of overall chain slack. The pitch of consecutive chain links may also change, which in turn can affect how the chain links engage and mesh with the sprockets. This can cause the chain to jump the sprocket teeth and can also accelerate sprocket wear.

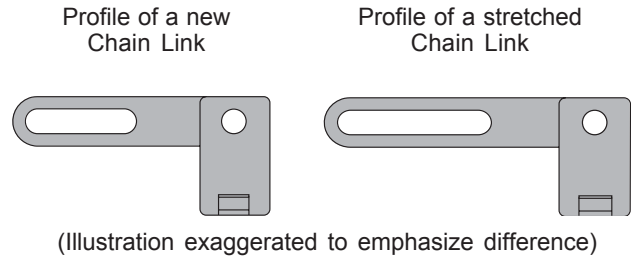

Figure 130

Figure 130 illustrates an exaggerated comparison of a new chain link to a stretched chain link.

Chain Pitch

Chain pitch refers to the distance from one point on a chain link to the same point on the next chain link, when the chain is fully extended (*Figure 131*).

A conveyor's chain pitch can change over time. Various factors can play a part in increasing the chain pitch in a conveyor chain. The changes in chain pitch are usually dependent on the amount of chain pull involved. As the chain pull increases, the chain pitch increases by a greater amount and at a faster rate. Conveyors that run at low speeds with large loads may experience a faster growth in chain pitch. A conveyor that has a relatively complex layout, including horizontal and/or vertical bends, requires a great amount of driving torque which may also affect the chain pitch.

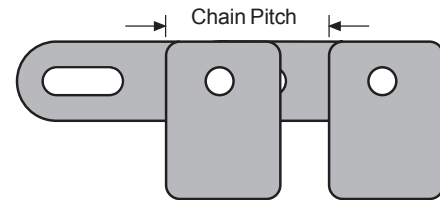

Figure 131

When a conveyor's chain pitch has changed significantly, the result is apparent. The sprocket teeth may be excessively worn or broken, the chain may be jumping the sprocket teeth, the drive/idler wearstrips may be damaged, or the chain links may be breaking. Correcting these symptoms will not solve the overall problem. The chain itself must be replaced. To determine if a conveyor's chain pitch is out of the allowable range, the chain pitch must be measured correctly. The chain's elongation percentage can then be determined and compared to the maximum recommended allowance.

Part X: Chain Pitch & Elongation

Procedure for Finding a Chain's Elongation Percentage

Find a fully extended length of chain along the conveyor that includes at least ten links. Measure from one end of this length of chain to the other, beginning at some point on the first side link and ending at the same point on the last side link (see *Figure 132*).

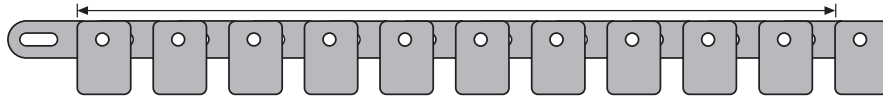

Figure 132

Use this distance to calculate the chain's elongation percentage, by the following formula:

$$\% \text{ Elongation} = \left[\frac{\text{Distance Measured} - (\text{Normal Pitch} * \text{No. of Links Measured})}{\text{Normal Pitch} * \text{No. of Links Measured}} \right] \times 100$$

- * Normal Pitch for MonoSpan chain = 0.984" (25mm)
- * Normal Pitch for MultiSpan chain = 0.984" (25mm)
- * Normal Pitch for MaxiSpan chain = 1.969" (50mm)

If the elongation percentage calculated is greater than 4% for MonoSpan and MultiSpan chain, or 2% for MaxiSpan chain, the conveyor's chain should be replaced.

Chemical Compatibility Chart

The following multi-page chart (*pages 90-97*) provides chemical compatibility information for a variety of materials used in Designer System[®] conveyor components. The information is based on testing of the component materials' compatibility with a wide range of chemical reagents.

The materials used in Designer System[®] conveyors include the following:

- **Acetal** – Chain links, MaxiSpan chain rods, chain lock tabs
- **LDPE** – Drive/idler hole plugs
- **Nylon** – Wearstrip rivets
- **Polypropylene** – Drive/idler side plates, vertical bends
- **Polyurethane** – High Friction chain links
- **Santoprene 55** – High Friction chain links
- **Santoprene 87** – High Friction chain links, drive/idler bearing shields
- **Spanlon** – Wearstrips
- **Super Tough Nylon** – Sprockets
- **UHMW-PE** – Center Support Rails, Guide Rails

Reagent	Acetal	LDPE	Nylon 66	Polypropylene	Polyurethane	Santoprene 55	Santoprene 87	Spanlon	Super Tough Nylon	UHMW-PE
Acetaldehyde	A	LR	A		NR					
Acetic Acid (5%-10%)	A	A	LR	A	LR	A	A		LR	A
Acetic Acid (50%-75%)	NR	A	NR	A		A	A		NR	
Acetic Acid (80%-95%)	NR	LR	NR	A	NR	A	A		NR	A
Acetic Acid - Glacial	NR		NR	A	NR	A	A		NR	
Acetic Anhydride		NR		A	NR					
Acetone	A	NR	A	A	NR			A		A
Acetophenone	A		A	LR						
Acetyl Chloride	NR		NR							
Acetylene	A		A		A					
Adipic Acid	A									
Allyl Alcohol		NR	LR						LR	
Aluminum Chloride	A	A	A	A	A					A
Aluminum Fluoride		A		A						
Aluminum Hydroxide	A			A						
Aluminum Sulfate	A	A	A	A	A					
Alums		A		A	A					
Ammonia	A		A	A						A
Ammonium Acetate			A							
Ammonium Carbonate		A	A	A						
Ammonium Chloride	A	A	A	A	A					
Ammonium Fluoride		A		A						
Ammonium Hydroxide	VLR	A	NR	A						
Ammonium Nitrate		A		A						A
Ammonium Sulfate		A		A	A					
Amyl Acetate	A	NR	A	LR	NR					
Amyl Alcohol	A	A	LR	A	LR				LR	
Aniline	LR	A	LR	A	NR	A	A			A
Antifreeze	A		A			A	A			
Aqua Regia	NR			LR						
Barium Chloride		A	A	A	A					
Barium Hydroxide		A		A						
Beer		A		A	A					A

A = Acceptable LR = Limited Resistance VLR = Very Limited Resistance NR = Not Resistant

Reagent	Acetal	LDPE	Nylon 66	Polypropylene	Polyurethane	Santoprene 55	Santoprene 87	Spanlon	Super Tough Nylon	UHMW-PE
Benzaldehyde	A		A	A	NR					
Benzene	A	NR	A	LR	NR					LR
Benzoic Acid	LR	A	VLR	A					VLR	
Benzyl Alcohol	A		LR	A					LR	A
Bleach		A	LR						LR	A
Borax		A		A	A					
Boric Acid	A	A	A	A	A					
Brake Fluid	A		A	A		A	A	A	A	
Bromine	NR	NR	NR	NR					NR	
Butane	A		A		A					
Butanol	A		A		LR					
Butyl Acetate	A	LR	A	NR	NR	A	A			
Butyl Alcohol		A	A	A	LR					A
Butyric Acid	NR	NR	A							A
Calcium Chloride	A	A	A	A	A	A	A	A		A
Calcium Hydroxide	A	A		A						
Calcium Hypochlorite		A	NR	A						
Calcium Nitrate	A	A		A						
Calcium Sulfate	A	A		A						
Carbon Dioxide	A	A		A	A					
Carbon Disulfide	A	NR	A	NR	LR					
Carbon Monoxide	A	A		A						
Carbon Tetrachloride	A	NR	A	NR	NR					LR
Chlorine	NR	NR	NR	LR	NR				NR	
Chloroacetic Acid	NR	NR	NR	A					NR	
Chloroform	LR	NR	A	VLR	NR				LR	
Chlorosulfonic Acid		NR	NR	NR					NR	
Chromic Acid (10%-20%)	NR	A	NR	A						
Chromic Acid	NR	A		A	NR					A
Citric Acid	A	A	A	A						A
Clorox			NR	A					NR	
Copper Chloride	A	A	VLR	A						
Copper Sulfate	A	A	A	A	A					

A = Acceptable LR = Limited Resistance VLR = Very Limited Resistance NR = Not Resistant

Reagent	Acetal	LDPE	Nylon 66	Polypropylene	Polyurethane	Santoprene 55	Santoprene 87	Spanlon	Super Tough Nylon	UHMW-PE
Corn Oil			VLR	A					A	
Cottonseed Oil		A		A					A	
Cresol		A	NR	A	NR				NR	
Crude Oil	A				A				A	
Cyclohexane			A	A	NR	NR	VLR			A
Cyclohexanol	A	A	A	A						A
Cyclohexanone	A	NR	A	LR	NR					
Decalin	A		A	NR						
Detergent	A	A	A	A	A	A	A		A	A
Dibutyl Phthalate	A	LR	A	A	LR					
Diesel Fuel	A		A		A					
Diethyl Ether	A			LR	LR	A	A			
Dimethyl Formamide	A				NR	A	A			
Dioctyl Phthalate	A	LR	A		LR	A	A			
Dioxane	A		A	A		VLR	A			
Ethanol	A		A	A	LR	A	A	A		A
Ethyl Acetate	A	LR	A	A	NR					A
Ethyl Alcohol	A	A	LR	A	LR					
Ethylene Chloride	A	NR	A	NR						
Ethylene Dichloride	A	VLR	A	LR					LR	
Ethylene Glycol	A	A	LR	A	LR	A	A			A
Ethylene Oxide	A		A	A						
Ferric Chloride	A	A	A	A	A					
Ferric Sulfate	A	A	A	A						
Ferrous Sulfate		A		A						
Ferrous Chloride	A	A	A	A						
Fluoboric Acid		A	NR						NR	
Fluorine	NR	A	NR	NR					NR	
Fluorosilicic Acid		A	NR	A					NR	
Formaldehyde (@37%)	A	A	A	A	LR					
Formic Acid (80%-85%)	NR	A	NR	A	NR				NR	
Freon 12			A		LR					
Furfural	A	NR		NR						

A = Acceptable LR = Limited Resistance VLR = Very Limited Resistance NR = Not Resistant

Reagent	Acetal	LDPE	Nylon 66	Polypropylene	Polyurethane	Santoprene 55	Santoprene 87	Spanlon	Super Tough Nylon	UHMW-PE
Gasoline	A	NR	A	LR					A	
Glycerin		A	A	A	A	A	A			A
Heptane	A	NR	A	NR	A					
Hexane	A		A	A	A	VLR	A			
Hydraulic Fluid	A		A	A	A					
Hydrobromic Acid	NR	A	NR	A					NR	
Hydrochloric Acid	NR	A	NR	A	NR	A	A	A	NR	A
Hydrocyanic Acid	NR		NR						NR	A
Hydrofluoric Acid	NR	A	VLR	A	LR				NR	A
Hydrogen Peroxide	NR	A	NR	LR					NR	A
Hydrogen Sulfide	A	A	A	A						
Hypochlorous Acid	NR	A	NR						NR	
Isooctane	A		A	NR		VLR	A		A	
Isopropyl Alcohol	A		LR	A	LR				LR	
Kerosene	A		A	LR	LR			A		
Lactic Acid	LR	A	A	A	LR					
Lestoil (@ 2%)	A		VLR	NR						
Magnesium Chloride	A	A	A	A	A					
Magnesium Sulfate		A	A	A						
Maleic Acid	LR	A								
Methyl Ethyl Ketone	LR	NR	A	A	NR	VLR	A	A		
Mercury	A	A	A	A	A					
Methanol	A	A	A	A	LR			a	A	
Methyl Alcohol	A	A	LR	A	LR				LR	
Methyl Chloride	A	LR	A	NR						
Methyl Isobutyl Ketone			A	A	NR					
Methylene Chloride	LR		LR	A	NR				NR	
Milk	A	A	A	A	A					A
Mineral Oil	A	LR	A	A	A				A	
Motor Oil	A	A	A	A	A				A	
Naphtha (VMP)	A	A	A	A	LR					
Naphthalene	A	NR	A	A						
Natural Gas	A				A					

A = Acceptable LR = Limited Resistance VLR = Very Limited Resistance NR = Not Resistant

Reagent	Acetal	LDPE	Nylon 66	Polypropylene	Polyurethane	Santoprene 55	Santoprene 87	Spanlon	Super Tough Nylon	UHMW-PE
Nitric Acid (@ 10%)	NR		NR	A					NR	A
Nitric Acid (@ 70%)	NR	A	NR	VLR					NR	LR
Nitrobenzene	A	NR	LR	A		A	A			
Oleic Acid	A	LR	A	A						A
Oleum	NR	NR	NR	NR						
Oxalic Acid	NR	A	A	A						
Ozone	VLR	LR	LR	NR	A					
Perchloric Acid	NR	A	NR							
Perchloroethylene	LR		A	NR	NR					
Petroleum Ether	A	NR	A	VLR	LR				NR	A
Phenol	NR	NR	NR	A	NR				NR	
Phosphoric Acid (@ 10%)	VLR	A	NR	A					NR	
Phosphoric Acid (@ 85%)	NR	A	NR	A					NR	A
Potassium Bicarbonate	A	A	A	A						
Potassium Bromide (sat.)	A	A	A	A						
Potassium Carbonate	A	A	A	A						
Potassium Chloride	A	A	A	A						
Potassium Dichromate	A	A	LR	A	A					
Potassium Hydroxide	A	A	VLR	A	A	A	A			A
Potassium Nitrate	A	A	A	A	A					
Potassium Permanganate	A	A	NR	A						
Potassium Sulfate	A	A	A	A	A					
Propane	A		A		A	A	A			
Pyridine	LR		A	A	NR	A	A		A	
Silicone Oil	A		A	A					A	
Soap Solution	A	A	A	A					A	
Sodium Bicarbonate	A	A	A	A	A					
Sodium Bisulfite	NR	A	A	A						
Sodium Carbonate	A	A	A	A						A
Sodium Chloride	A	A	A	A	A	A	A			A
Sodium Hydroxide (@ 10%)	A	A	A	A						
Sodium Hydroxide	A	A	A	A		A	A			A
Sodium Hypochlorite (@ 15%)	VLR	A	NR	A						A

A = Acceptable LR = Limited Resistance VLR = Very Limited Resistance NR = Not Resistant

Reagent	Acetal	LDPE	Nylon 66	Polypropylene	Polyurethane	Santoprene 55	Santoprene 87	Spanlon	Super Tough Nylon	UHMW-PE
Sodium Sulfate		A	A	A						
Sodium Sulfide	A	A	A	A	A					
Stannous Chloride	A	A	LR	A						
Stannous Chloride	NR	A		A						
Stearic Acid	A	A	A							
Styrene	A		A		LR					
Sulfur			A	A	LR					
Sulfur Dioxide, Dry	NR	A								
Sulfur Dioxide, Moist	NR	A								
Sulfuric Acid (@ 3%)								A		
Sulfuric Acid (@ 10%)	LR	A	VLR	A					NR	
Sulfuric Acid (@ 30%)	NR	A	VLR	A					NR	A
Sulfuric Acid (@ 98%)	NR	LR	NR	VLR		A	A		NR	A
Sulfurous Acid (conc.)		A	LR						NR	
Tannic Acid	LR	A	NR	A					NR	
Tartaric Acid	LR	A	A	A						
Tetrachloroethylene	A		A							
Tetrahydrofuran	LR	NR	A	LR						
Tetralin	A		A	LR						
Toluene	A	NR	A	NR	NR	NR	VLR	A	A	LR
Transformer Oil	A	LR	A	A	LR				A	
Trichloroacetic Acid	NR		NR	A					NR	
Trichloroethane	A		LR		NR					
Trichloroethylene	NR	NR	LR	NR	NR	NR	NR	A		LR
Tricresyl Phosphate			A	A	NR					
Triethanolamine	A	A	A	A						
Trisodium Phosphate		A		A	LR					
Turpentine	A	LR		LR	A	NR	VLR			
Unocal Drillube 100	A		A	A					A	NR
Urea		A	A	A						
Vaseline	A		A						A	
Vegetable Oils	A		A	A					A	
Vinegar		A	A		A					

A = Acceptable LR = Limited Resistance VLR = Very Limited Resistance NR = Not Resistant

Reagent	Acetal	LDPE	Nylon 66	Polypropylene	Polyurethane	Santoprene 55	Santoprene 87	Spanlon	Super Tough Nylon	UHMW-PE
Wax	A		A							
Wines	A	A	A	A	A					A
Xylene	A	NR	A	VLR	NR	NR	VLR			LR
Zinc Chloride	NR	A	VLR	A	A	A	A	A	NR	A
Zinc Oxide			A	A						
Zinc Sulfate	A	A	A	A						

NOTE: This is not an exclusive list. If an unlisted or untested chemical is in question, have a qualified testing laboratory run a test using conveyor components to determine the chemical's effect.

NOTE: All tests performed to produce the given results were conducted in an ambient temperature of 70°F (21°C).

SOURCES: Plastics Design Library (William Andrew, Inc.)
 Santoprene Thermoplastic rubber - fluid resistance (Advanced Elastomer Systems)
 Engineering Plastics for Industry (Solidur Plastics Company)

A = Acceptable LR = Limited Resistance VLR = Very Limited Resistance NR = Not Resistant

Troubleshooting Diagnostic Chart

The following diagnostic chart (*page 99*) is designed to serve as a troubleshooting aid when attempting to solve problems with a conveyor system. Some obvious defects in the conveyor system, uncovered while investigating the conveyor and environment, may not be shown directly on the chart. The corrective action for these defects should be included in the plans for the corrective repairs.

If you find problem descriptions and/or probable causes that should be added to this chart, be sure to let the Span Tech customer service manager know, so that it can be included on future charts.

Troubleshooting Diagnostic Chart

NOTICE

While this chart contains a comprehensive set of problem descriptions and probable causes, it cannot replace a thorough examination and investigation of the conveyor system. The intended use of this diagnostic chart is to assist troubleshooters in reviewing the results of their investigation.

PROBLEM DESCRIPTION

PROBABLE CAUSES	PROBLEM DESCRIPTION														
	Breaking drive and / or idler sprockets	Breaking chain links	Breaking chain rods	Excessive wear on the inside chain surface	Excessive wear on the outside (product) chain surface	Motor running at high amperage	Breaking drive and / or idler side plates	Chain disengaging from the conveyor side frame	No clearance between chain and wearstrip	Product will not incline / decline	Excessive wear on side link chain legs	Excessive wear on side link chain feet	Wearstrip becomes detached from side frame	Wearstrip in curve discolored on outer edge	Chain jumping teeth on sprockets
Contamination of the chain and/or wearstrips	✓	✓	✓	✓	✓	✓	✓	✓	✓	✓	✓	✓	✓	✓	
Interference from foreign objects	✓	✓	✓	✓	✓	✓	✓	✓	✓	✓	✓	✓	✓	✓	✓
Improper sprocket assembly	✓	✓	✓			✓	✓								✓
Misalignment of sprockets	✓	✓	✓			✓	✓								✓
Improper sprocket / chain engagement	✓	✓	✓			✓	✓								✓
Idler sprockets not rotating freely	✓	✓	✓			✓				✓	✓				✓
Improper wearstrip installation	✓	✓	✓			✓	✓	✓	✓		✓	✓	✓	✓	
Overlapping wearstrip	✓	✓	✓			✓		✓		✓	✓		✓		
Damaged wearstrip	✓	✓	✓			✓	✓	✓	✓		✓	✓		✓	
Broken drive / idler wearstrip	✓	✓	✓			✓		✓	✓		✓	✓			
Missing wearstrip								✓			✓	✓			
Broken chain links / rods / lock tabs		✓	✓			✓		✓						✓	
Improper amount of chain slack	✓			✓		✓									✓
Backward chain installation	✓	✓	✓												
Improper center support rail installation				✓		✓		✓		✓	✓		✓		
Improper return chain support installation					✓	✓		✓		✓	✓		✓		
Misaligned conveyor bed sections		✓	✓			✓		✓		✓	✓		✓		
Damaged conveyor side frame		✓	✓			✓		✓		✓	✓		✓		
Missing crossbars		✓	✓			✓		✓		✓	✓		✓		
Bound idler shaft	✓	✓	✓			✓								✓	✓
Loose and / or missing fasteners		✓	✓			✓		✓		✓	✓		✓	✓	✓
Chemical contamination	✓	✓	✓	✓	✓	✓	✓		✓	✓	✓		✓		
Chain's % elongation exceeded	✓	✓													✓



*Span Tech LLC
1115 Cleveland Avenue
P. O. Box 369
Glasgow, KY 42142
(270) 651-9166
general_info@spantechllc.com
www.spantechllc.com*