

HO-Series

HO-Series
Horizontal Offset Conveyors

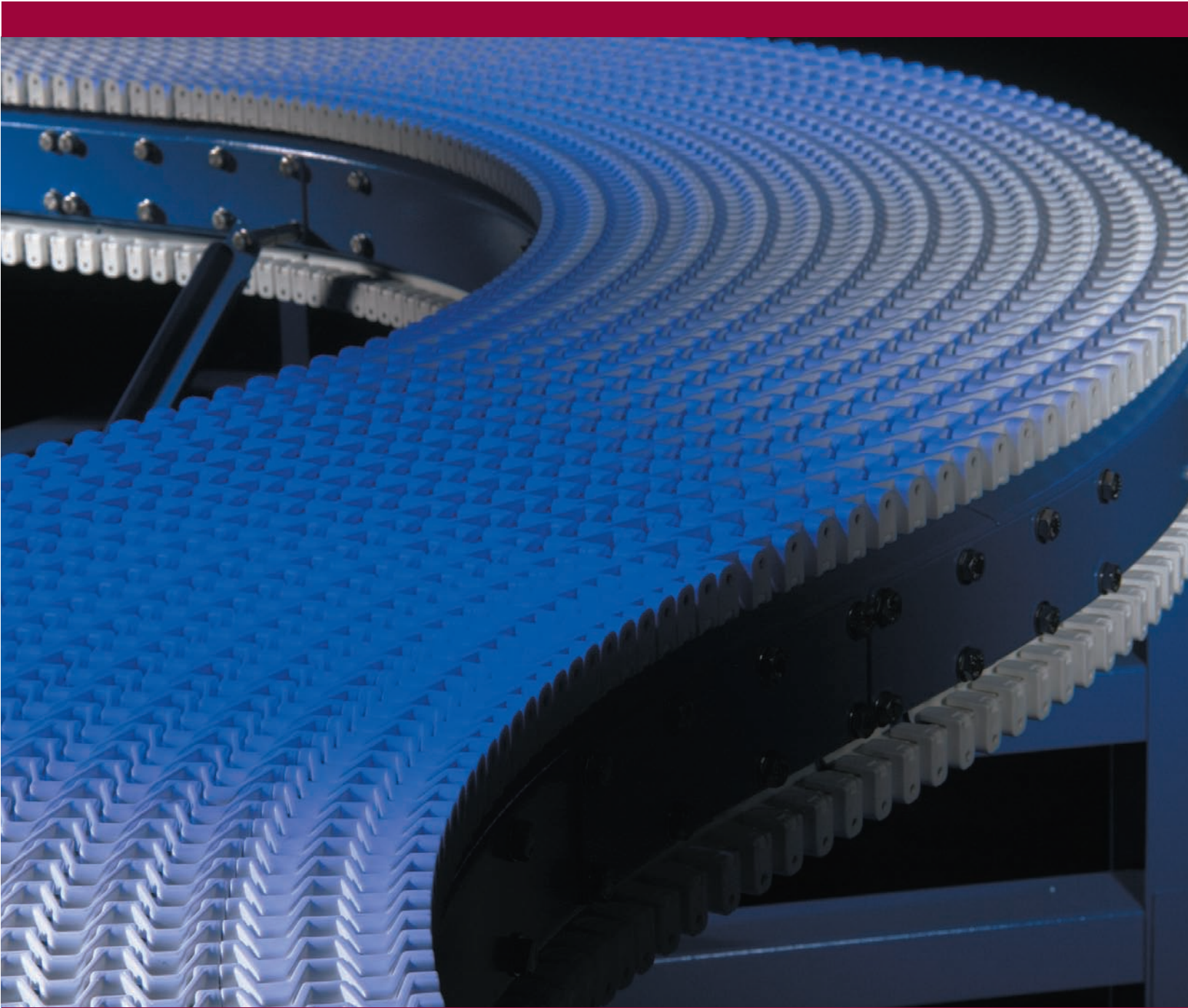

your Material Handling Specialist

HO-Series

Engineered for dependable, nearly maintenance-free operation.
Flexibility in turning radius and straight length for almost any configuration.

The Span Tech HO-Series is a horizontal offset conveyor. The HO-Series has two curves in opposite directions where the entrance and exit straight sections are parallel. Features variable length of the straight section between curves, and between the curves and the end of the conveyor. You can also choose the angle of the curves for optimum control.

Features & Benefits:

- ◆ Six (6) belt widths available for a variety of applications
- ◆ Choose between 30-, 45-, and 90-degree curves (each curve has the same angle)
- ◆ Speed range of 5 to 75 feet per minute (1.5 to 22.9 meters per minute)
Custom speed ranges available
- ◆ Increased load carrying capacity over a belt style conveyor
- ◆ Durable acetal chain provides long life, is completely self-tracking, and is nearly silent running
- ◆ The HO-Series chain has a 22% open area. This allows debris to pass through the conveyor chain
- ◆ Two-piece drive and idler sprockets for ease of replacement without shaft removal
- ◆ Non-corroding stainless steel drive shaft and idler shaft
- ◆ Non-corroding stainless steel fasteners
- ◆ Nominal top of chain ranges from 22 inches (558.8mm) to 84 inches (2133mm).
- ◆ SpanLon wear strip and center support rails provide long-wearing, silent operation
- ◆ See individual models for minimum product size capability
- ◆ There are no "take ups" with Span Tech conveyors, as you have with belt conveyors

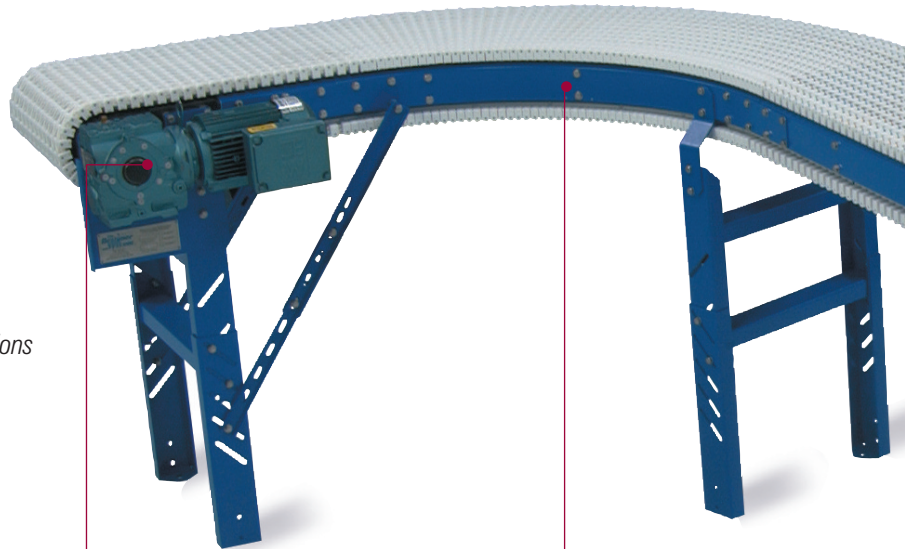

Gearmotor

SEW Eurodrive S Series Shaft Mounted Helical Worm Drive, 230 or 460 volt (3 phase) operation

Conveyor framing

Base material is steel, coated with blue epoxy powder coat paint for a long lasting finish

S

Conveyor Chain

White, acetal plastic with stainless steel hinge rods for long life

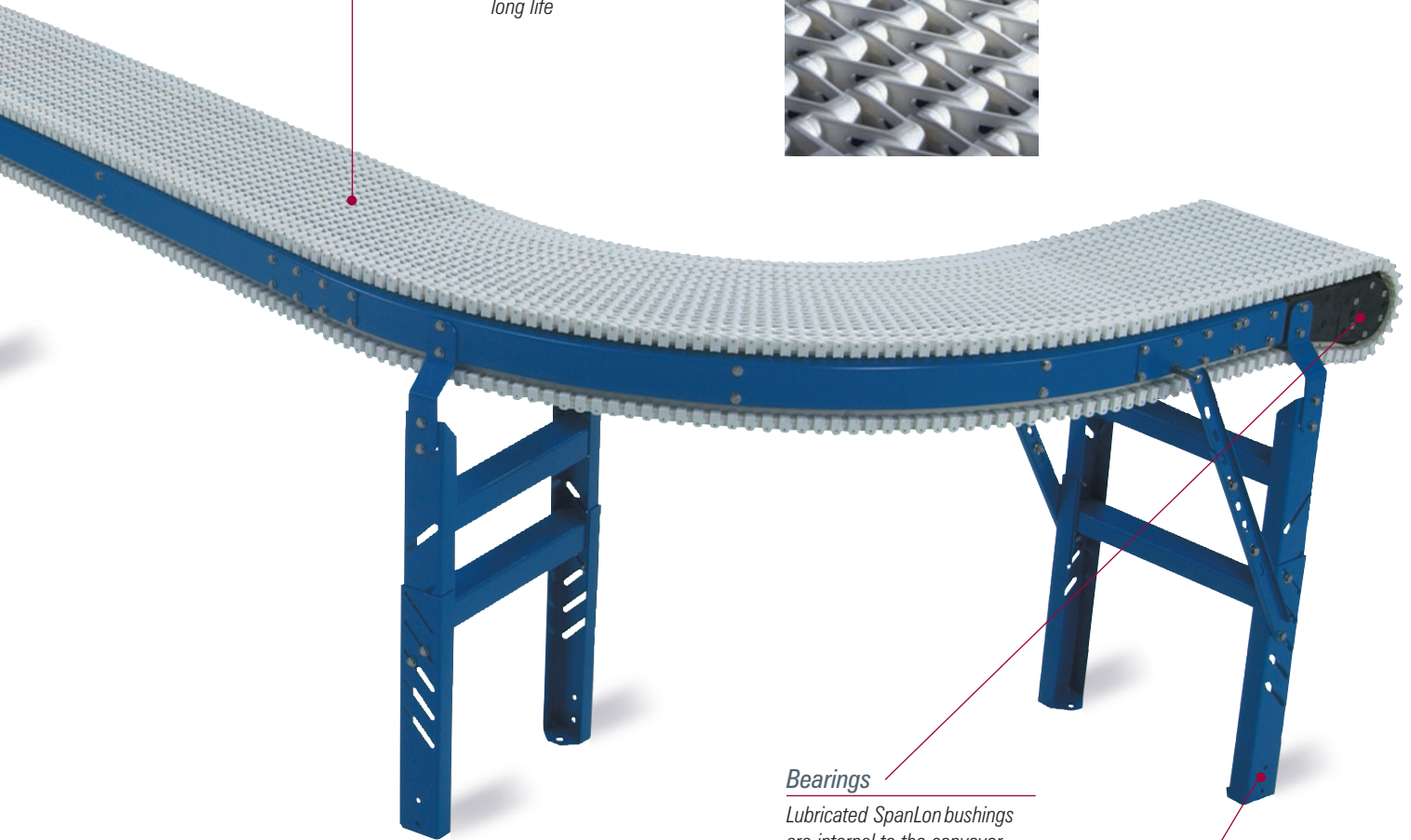
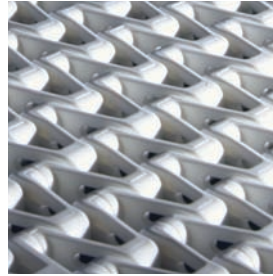

Bearings

Lubricated SpanLon bushings are internal to the conveyor frame

Foot Construction

Steel flange for easy anchoring

Ease of maintenance...



Chain can be taken apart at any link

HO-PLN Plain Chain

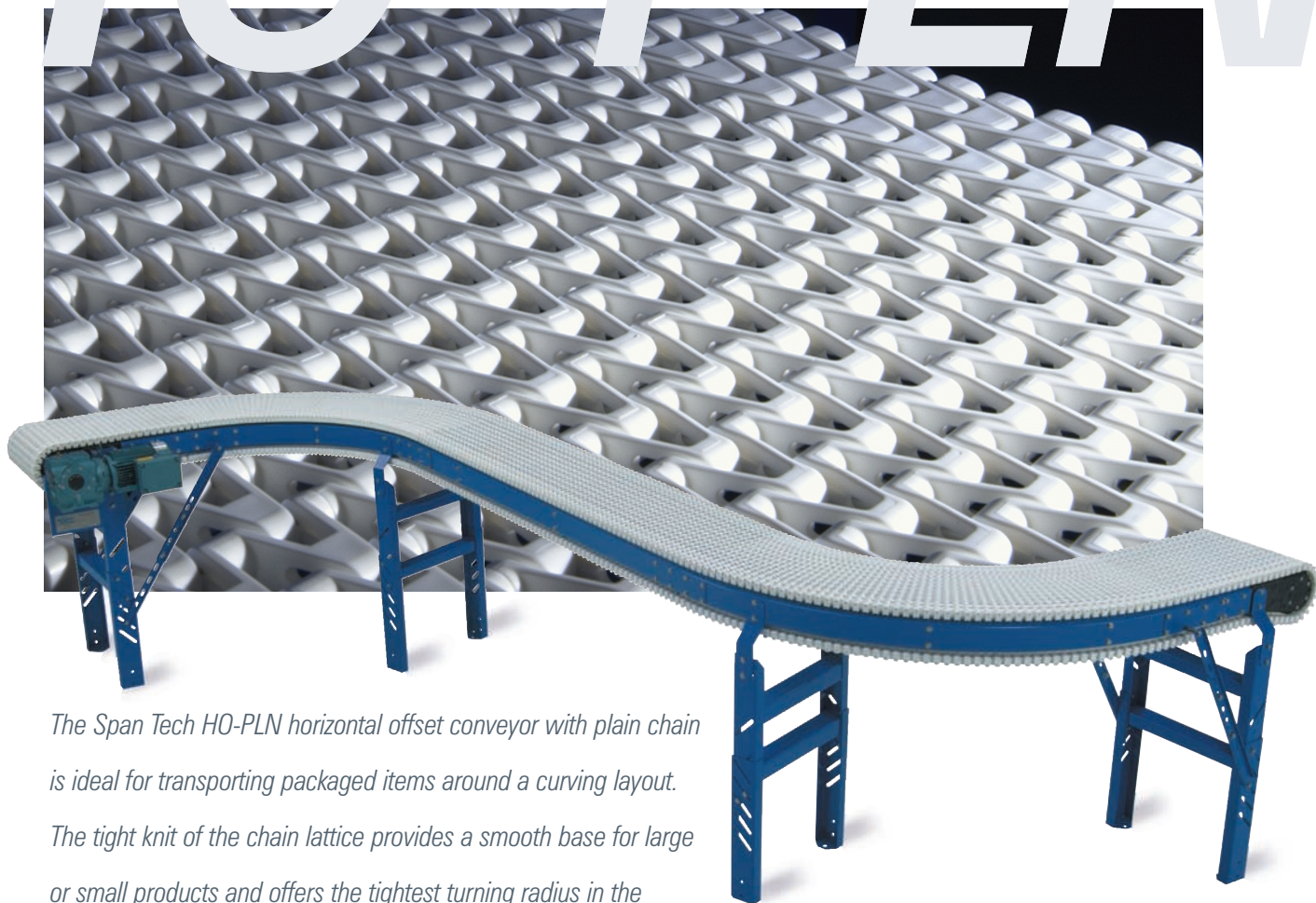

The Span Tech HO-PLN horizontal offset conveyor with plain chain is ideal for transporting packaged items around a curving layout.

The tight knit of the chain lattice provides a smooth base for large or small products and offers the tightest turning radius in the industry. The chain can support products down to 1 inch (25.4mm). If a Gravity Transfer is used, the minimum product size is 4.5" (114.3mm). The transfer is set to a decline angle of approximately 6°.

Ideal for ...

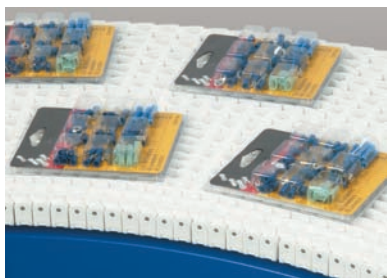

Order filling

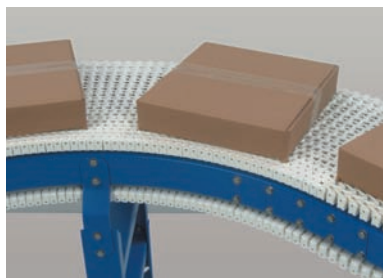

Carton transporting



End-to-end transfers

HO-PLN Specifications

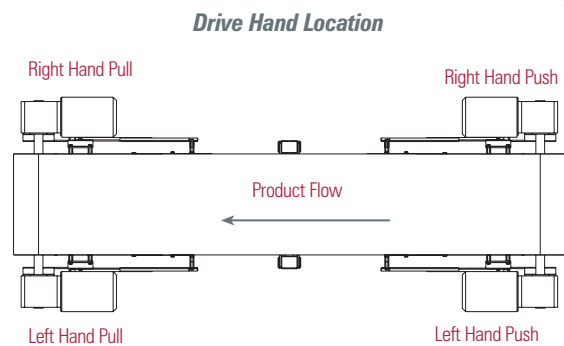
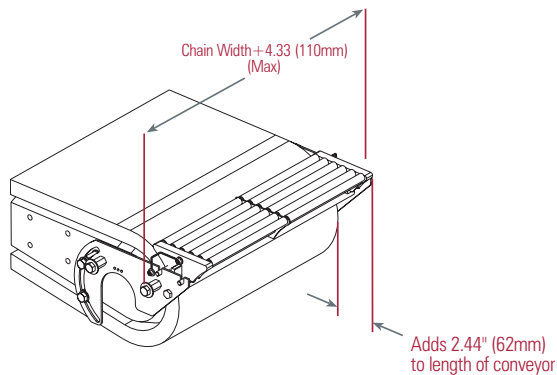
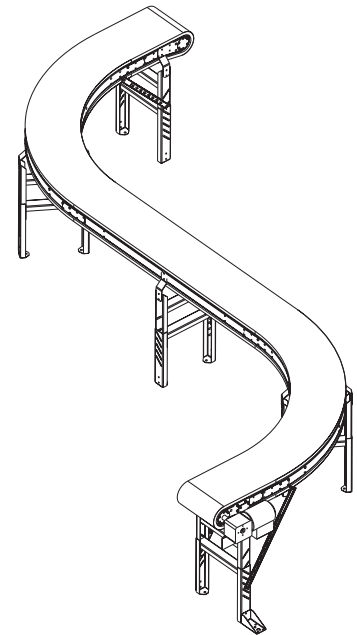
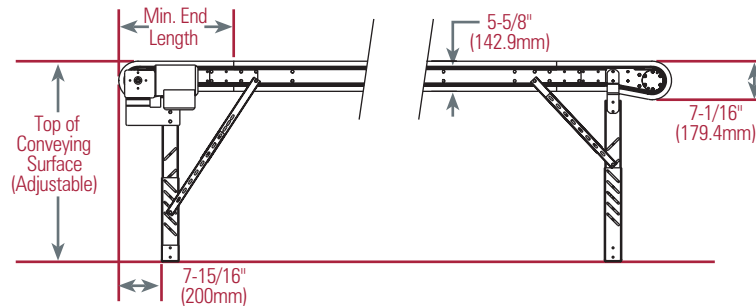
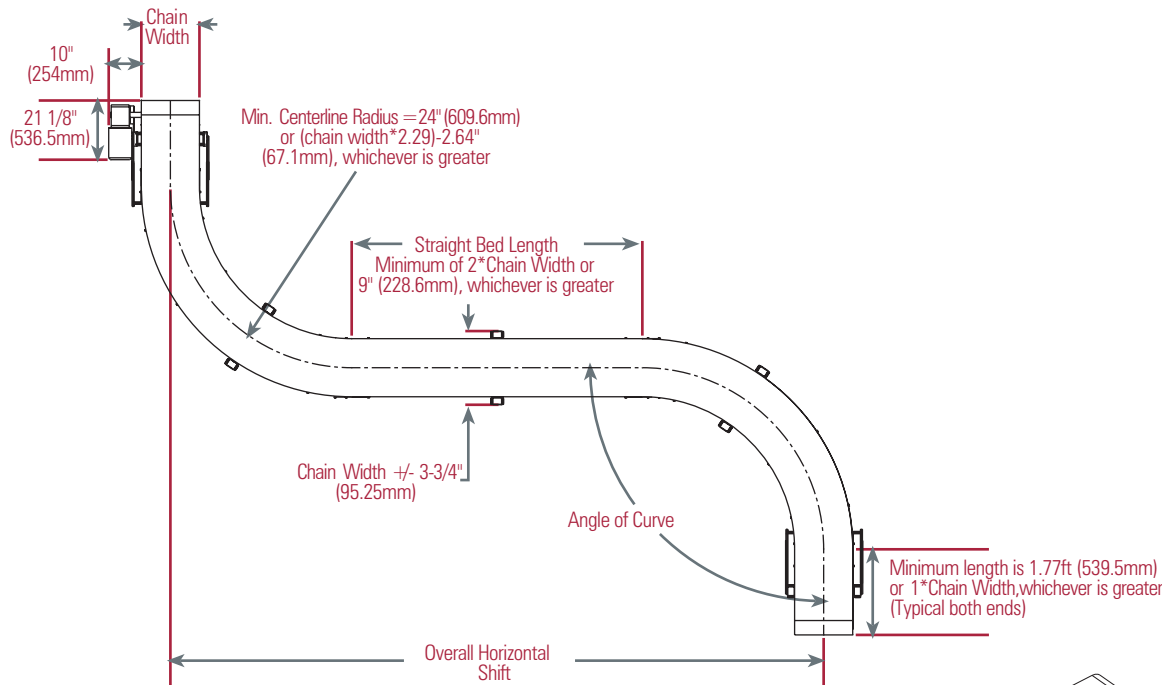

Note: Regardless of drive position the conveyor will run in either direction.

HO-RAS Raised Chain



Span Tech HO-RAS raised chain horizontal offset conveyor with a Finger Transfer can transfer products as small as 1.5 inches (38.1mm) in diameter. The transfer is set to a decline angle of approximately 10°. Raised top chain can also be used to reduce the amount of contact between the chain and the product, increasing airflow.

Ideal for ...

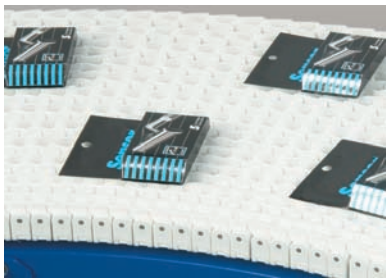

Delicate packaging



Small product



End-to-end transfers

HO-RAS Specifications

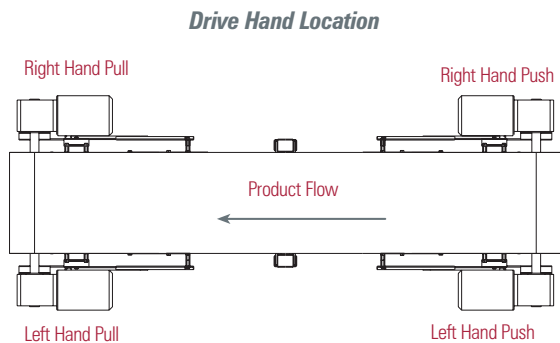
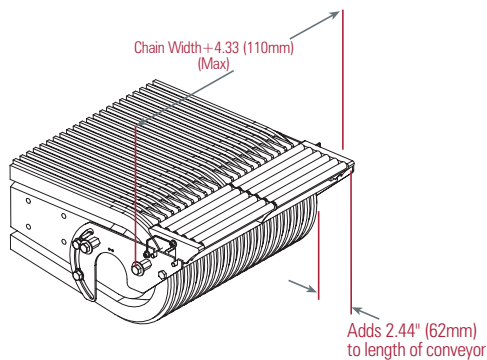
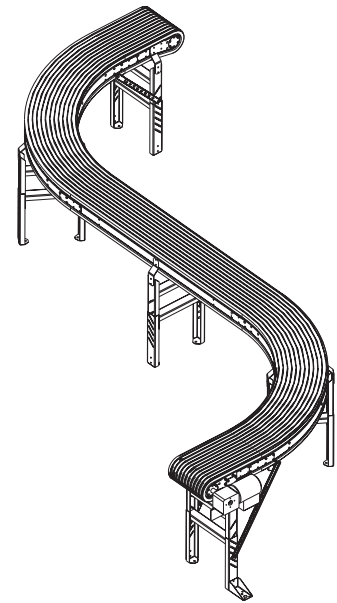
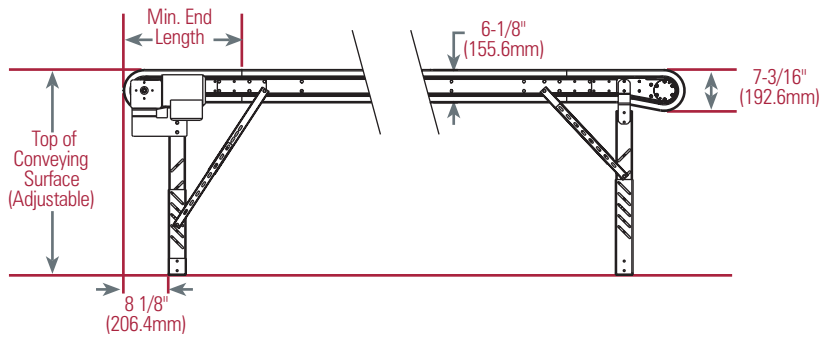
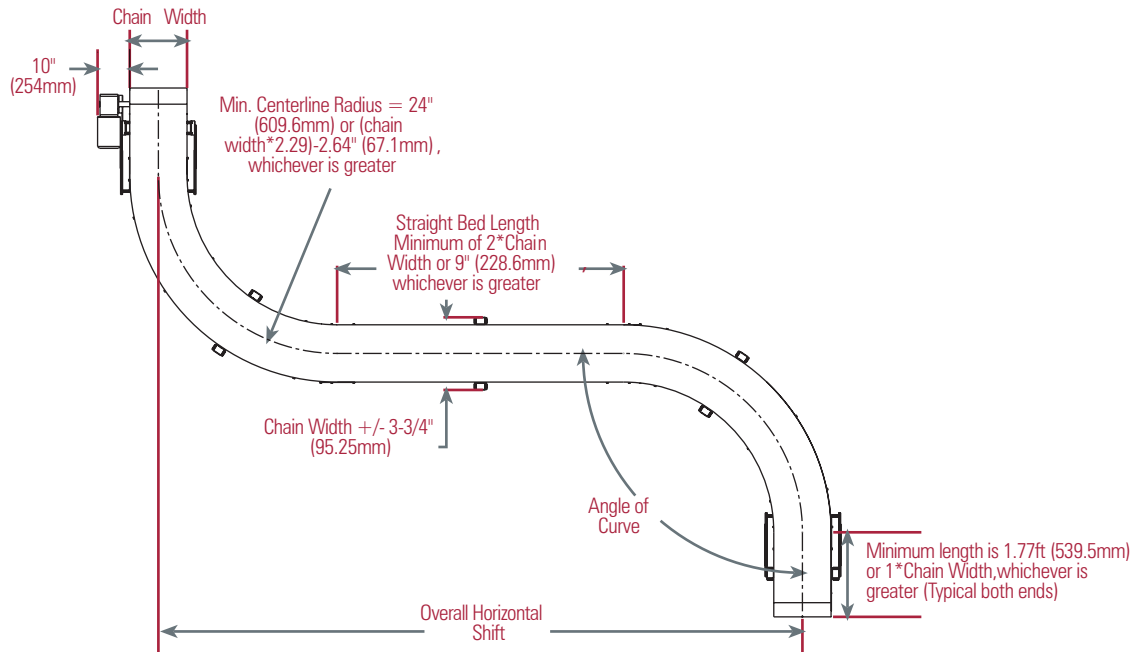

Note: Regardless of drive position the conveyor will run in either direction.

HO-MSG Moving Side Guide Chain

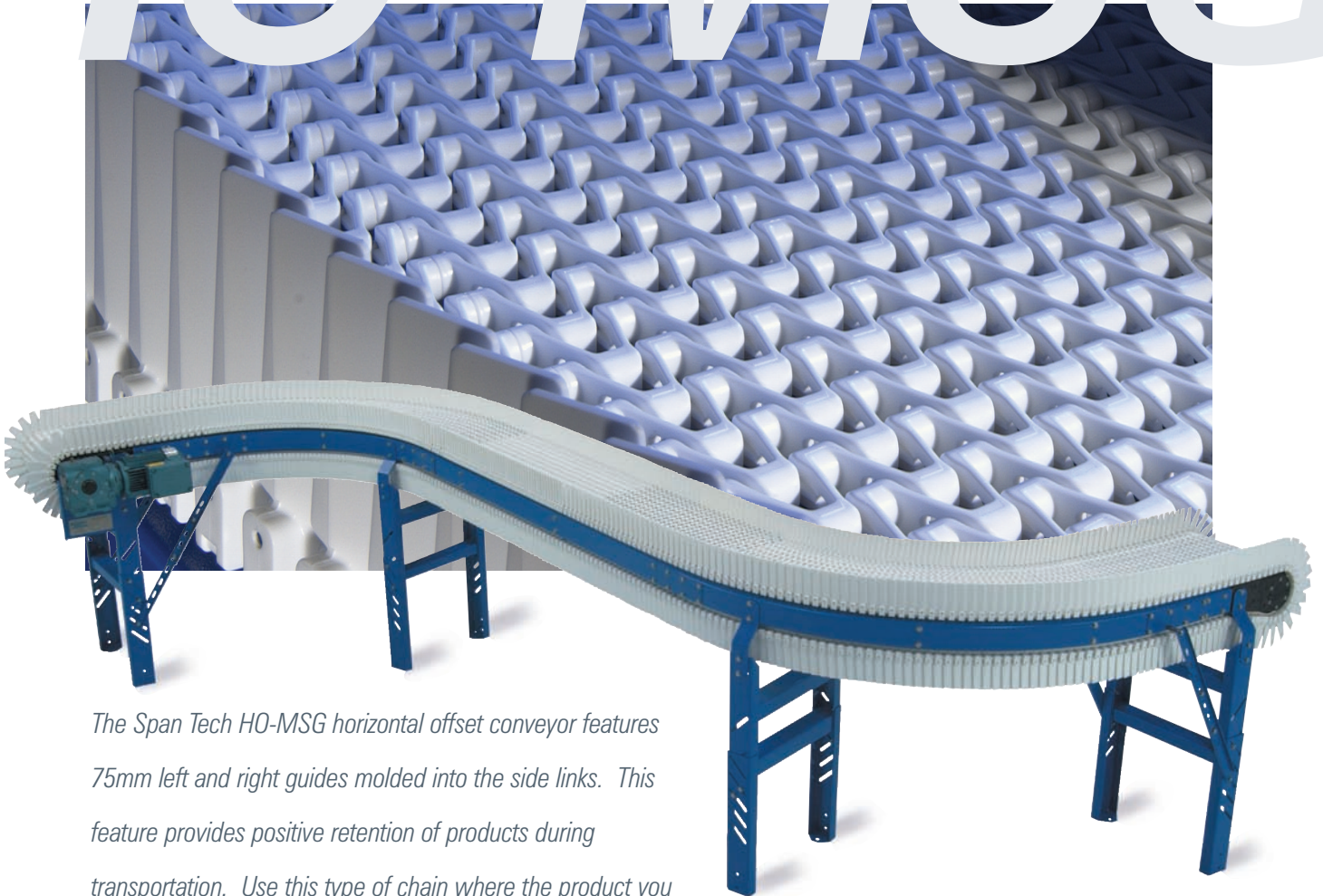

The Span Tech HO-MSG horizontal offset conveyor features 75mm left and right guides molded into the side links. This feature provides positive retention of products during transportation. Use this type of chain where the product you are moving might get tangled in conventional guide rails. Gravity Transfers are not available with this type of chain.

Ideal for...

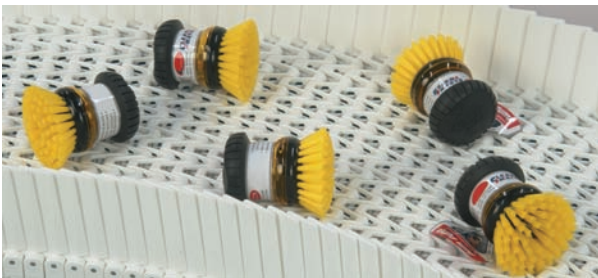

Irregular shapes



Bulk product

HO-MSG Specifications

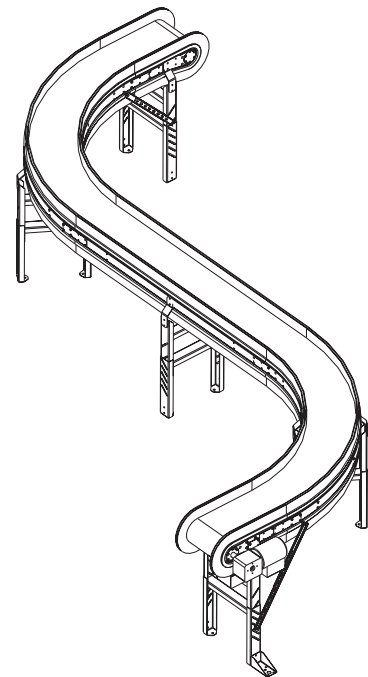
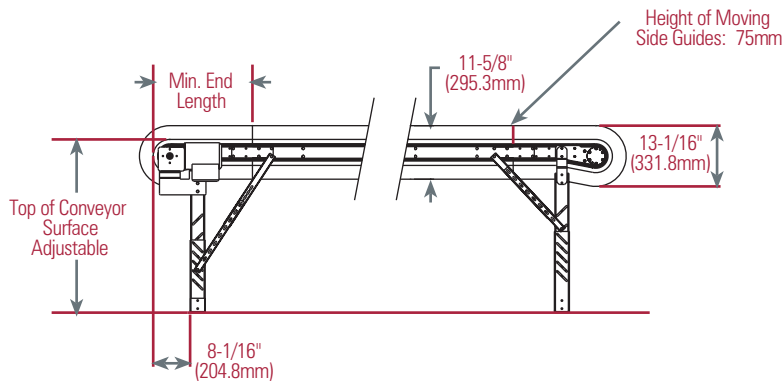
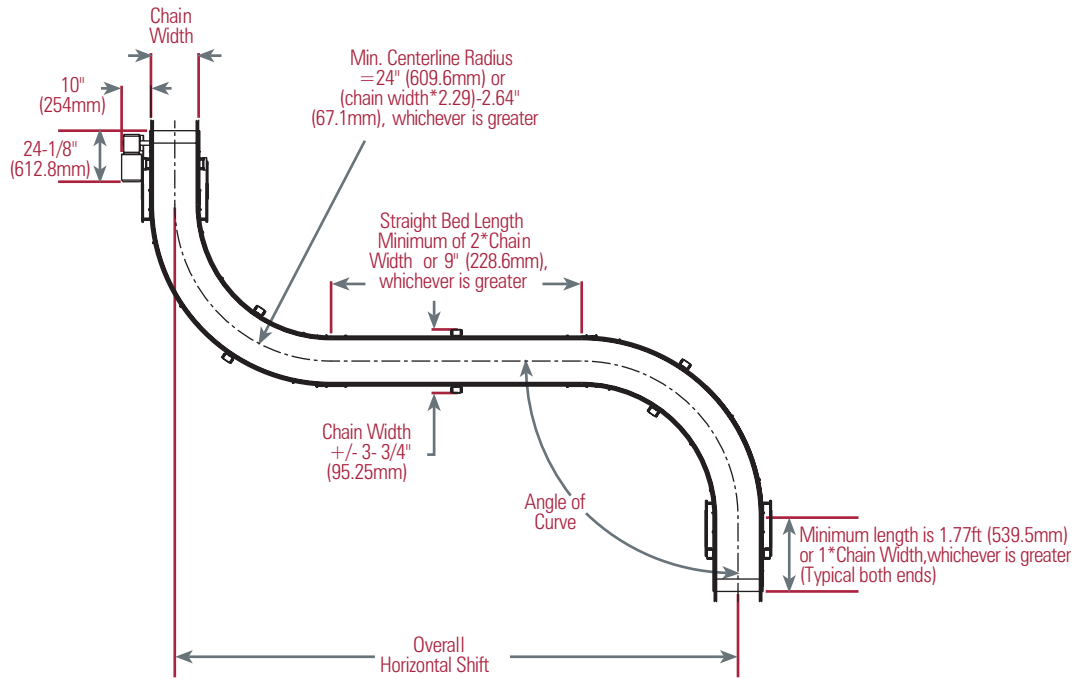

Drive Hand Location

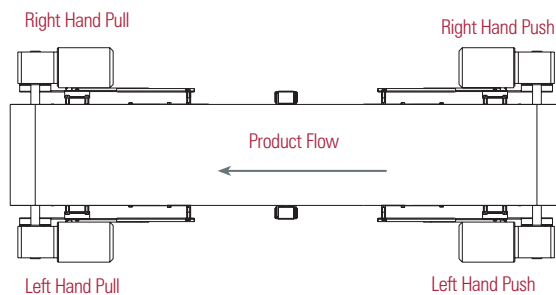

Note: Regardless of drive position the conveyor will run in either direction.

Options



Fixed Offset Guide Rail

Inside face of guide rail matches with edge of conveyor chain. The guide rail material is ultra-high molecular weight polyethylene with a galvanized steel back channel for durability. The guide rail comes in both 1.25 inch (31.8mm) and 2.25 inch (57.2mm) widths.



Gravity Transfer

This option permits transfer onto and off of the ends of the conveyor. These units lift out and are held in place by gravity as a safety feature to prevent objects from becoming lodged between the conveyor chain and the transfer rollers. The transfer uses small acetal rollers mounted on 4mm stainless steel rods. The unit is pitch adjustable from level to -15° at the discharge end and from $+15^{\circ}$ to level on the load end. See Transfer Guidelines chart for application guidelines.

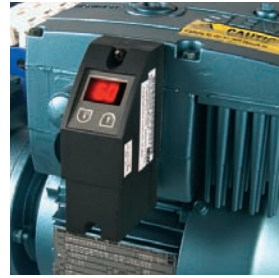

Movimot® Speed Controller

This is a frequency inverter built into the conduit box of the drive motor, with no external wiring other than your incoming power lines. Movimot® provides you with the lowest cost method of controlling the speed of your conveyor. The unit is capable of 200 to 500 volts AC and has a frequency range of 20 to 80 hertz. The unit features an integrated potentiometer for setting acceleration and deceleration times. It is IP65 hose proof/dust proof enclosed.

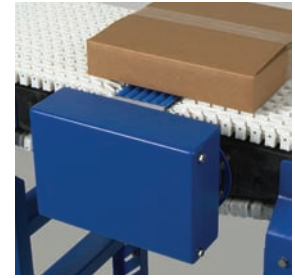

Slave Drive

The optional Slave Drive unit is available for plain and raised style chains. This option allows two different conveyors to be driven by a single gear-motor. Consult a Span Tech representative for compatibility with your system.



Articulated Foot

Made of plastic with a steel reinforced core and non-slip pad attached to the underside of the foot, these feet provide a freestanding support for the conveyor frame. Foot option increases top of chain elevation 5" (127mm).



Caster

4" (100mm) diameter locking caster for mounting on the conveyor leg. As a safety limitation, not available on conveyors weighing more than 800 lbs. (364 kilos). Foot option increases top of chain elevation 5" (127mm). The maximum conveyor height is 47" (119.4cm) for casters.

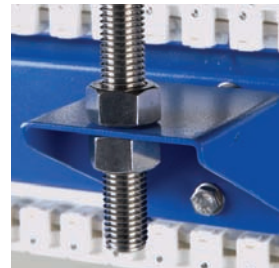

Ceiling Support Bracket

Painted mild steel brackets bolt to the side of the conveyor frame and support your system on 5/8" (15mm) hanger rods.

Options for HO Series Conveyors

	Fixed Offset Guide Rail	Gravity Transfer	Movimot Speed Controller	Slave Drive Capable	Articulated Foot	Caster	Ceiling Support Brackets
HO-PLN	•	•	•	•	•	•	•
HO-RAS	•	•	•	•	•	•	•
HO-MSG			•		•	•	•

HO-Series Specifications

Dynamic Load Capacity (not to exceed 50 lbs. Per Linear Ft.)

Chart is based on maximum conveyor lengths.

Standard Conveyor @ 65 FPM

H.P.	3.76" Chain Width* Total Load			7.31" Chain Width Total Load			10.85" Chain Width Total Load		
	30°	45°	90°	30°	45°	90°	30°	45°	90°
1/3 hp	575 lbs	469 lbs	295 lbs	445 lbs	420 lbs	262 lbs	415 lbs	370 lbs	196 lbs
1/2 hp	845 lbs	667 lbs	412 lbs	741 lbs	691 lbs	393 lbs	711 lbs	642 lbs	393 lbs
3/4 hp	845 lbs	667 lbs	412 lbs	978 lbs	889 lbs	589 lbs	919 lbs	839 lbs	546 lbs

H.P.	14.39" Chain Width Total Load			17.94" Chain Width Total Load			21.48" Chain Width Total Load		
	30°	45°	90°	30°	45°	90°	30°	45°	90°
1/3 hp	362 lbs	332 lbs	141 lbs	309 lbs	292 lbs	N/A	253 lbs	249 lbs	N/A
1/2 hp	664 lbs	612 lbs	329 lbs	618 lbs	558 lbs	256 lbs	570 lbs	526 lbs	167 lbs
3/4 hp	875 lbs	816 lbs	470 lbs	834 lbs	771 lbs	410 lbs	253 lbs	720 lbs	333 lbs

Curve must be placed a minimum distance away from the end of the conveyor at (1*Chain Width) or 1.77ft, whichever is greatest.

* 3.76" chain width is only available in PLN and RAS style chains

Dynamic Load Capacity (not to exceed 74 Kg Per Linear Meter)

Chart is based on maximum conveyor lengths.

Standard Conveyor @ 20 Meters/Minute

H.P.	95.5mm Chain Width* Total Load			185.7mm Chain Width Total Load			275.6mm Chain Width Total Load		
	30°	45°	90°	30°	45°	90°	30°	45°	90°
1/3 hp	261 kg	213 kg	134 kg	201 kg	190 kg	119 kg	188 kg	168 kg	89 kg
1/2 hp	383 kg	302 kg	187 kg	336 kg	313 kg	178 kg	322 kg	291 kg	178 kg
3/4 hp	383 kg	302 kg	187 kg	443 kg	403 kg	267 kg	416 kg	380 kg	247 kg

H.P.	365.5mm Chain Width Total Load			455.7mm Chain Width Total Load			545.6mm Chain Width Total Load		
	30°	45°	90°	30°	45°	90°	30°	45°	90°
1/3 hp	164 kg	150 kg	64 kg	140 kg	132 kg	N/A	115 kg	113 kg	N/A
1/2 hp	301 kg	277 kg	149 kg	280 kg	253 kg	116 kg	258 kg	238 kg	75 kg
3/4 hp	397 kg	370 kg	213 kg	378 kg	349 kg	186 kg	115 kg	326 kg	151 kg

Curve must be placed a minimum distance away from the end of the conveyor at (1*Chain Width) or 539mm, whichever is greatest.

* 95.5mm chain width is only available in PLN and RAS style chains

HO-Series Transfer Guidelines

Model & Chain Type	Transfer Type	Smallest Diameter Product Recommended	Maximum Height Recommended	Decline Angle of Transfer	Conveyor Speed Tested	Weight Tested
HO-PLN	Plain with rollers	4.5" (114.3 mm)	9" (228.6mm)	6°	65 fpm	97.8 oz. (2774 g)
HO-RAS	Finger Transfer	1.5" (38.1mm)	1.25" (31.75mm)	10°	65 fpm	1.45 oz. (41 g)
HO-MSG	Transfer not available	X	X	X	X	X

Information based upon controlled environment and specific product.

Smallest Recommended Product Diameter For Chain Surface

HO-PLN	1" (25.4mm)
HO-RAS	1.125" (28.6mm)
HO-MSG	1" (25.4mm)



*Span Tech LLC
1115 Cleveland Avenue
P. O. Box 369
Glasgow, Kentucky 42141
Phone: (270) 651-9166
general_info@spantechllc.com
www.spantechllc.com*